



**EUROPEAN ENERGY RESEARCH ALLIANCE**

# **Strategic Research and Innovation Agenda of the transversal Joint Programme Digitalization for Energy**

Version: 16

Last modification date: December, 15<sup>th</sup> 2020

Contact persons:

## Index

1 Summary .....	4
2 Introduction .....	6
2.1 Background .....	7
2.2 Strategic Leadership and added-value .....	9
2.3 Objectives .....	12
2.4 tJP Structure.....	13
3 Overview of Sub-programmes.....	15
3.1 SP1 – HPC.....	15
3.1.1 Background .....	15
3.1.2 Objective .....	16
3.1.3 Identified topics and expected output .....	18
3.1.4 Contacts .....	19
3.2 SP2 – Data Science & Artificial intelligence .....	19
3.2.1 Background .....	19
3.2.2 Objective .....	21
3.2.3 Identified topics and expected output .....	22
3.2.4 Contacts .....	23
3.3 ESI tSP “Technology” .....	23
3.3.1 Background .....	24
3.3.2 Objective .....	24
3.3.3 Identified topics and expected output .....	27
3.3.4 Contacts .....	27
3.4 AMPEA tSP “Multiscale modelling of materials, processes and devices” .....	28
3.4.1 Background .....	28
3.4.2 Objective .....	30
3.4.3 Identified topics and expected output .....	34
3.4.4 Contacts .....	34
3.5 Hydropower tSP “Digitalization” .....	34
3.5.1 Background .....	35
3.5.2 Objective .....	37
3.5.3 Identified topics and expected output .....	39
3.5.4 Contacts .....	39
3.6 Nuclear Materials tSP “Physical modelling, materials health monitoring and non-destructive microstructure examination for nuclear materials” .....	39
3.6.1 Background .....	40
3.6.2 Objective .....	41
3.6.3 Identified topics and expected output .....	42

3.6.4 Contacts .....	43
4 Management .....	44
4.1 Resources.....	45
4.1.1 Participants .....	45
4.1.2 Infrastructures and facilities .....	46
4.2 Committees and Boards .....	46
4.3 EERA Officers.....	47
4.3.1 Joint Programme Coordinator (JPC) .....	47
4.3.2. Deputy Joint Programme Coordinator (DJPC).....	48
4.3.3. Subprogramme Coordinator (SPC) .....	48
4.4 Bodies of EERA tJP DfE.....	48
4.4.1. Steering Committee (SC).....	48
4.4.2. Joint Programme Management Board (MB).....	49
4.4.3. Subprogramme management team (SPMT) .....	49
4.4.4. Members of the JPMB appointed by the JPSC .....	50
5 Risks.....	51
6 Intellectual Property Rights of the tJP.....	52
7 Contributors.....	53

## 1 Summary

EERA has revised its Mission into “catalysing European energy research to achieve a climate neutral society by 2050”. Also, a Clean Energy Transition should provide enough flexibility to accommodate the evolution of requirements over the coming years, and recognise the evolution of boundaries from other initiatives and programmes. EERA, therefore, proposes to define the Strategic Research and Innovation Agenda at the level of the “Challenge Driven Transition Initiatives” that will embed this level of flexibility, while ensuring that the nature of the societal challenge and its targeted impacts are met.

In this context, digitalization is identified as one of the technologies and initiatives that will enable this challenge-driven transition. Even more, digitalization should be perceived as an opportunity and an ‘enabler’ that will connect Energy technologies in a cross-cutting and holistic fashion.

Advanced digitalization can be enhanced by changing the way in which research is being done providing new results, impact, revenue, and value-producing opportunities, a fact that will have a positive impact in EERA’s community practices.

Under this scenario, it is a clear asset to count on a JP capitalizing the related EERA interests and priorities in order to improve the value chain in the energy sector carrying out specific research on the targeted topics, provide an important reference point for the EU research agenda, and ensure a better coordination with ongoing and future initiatives coming from the IT world.

In order to maximize the impact of digitalization as a cross-cutting activity within EERA, a new Joint Programme (JP) is conceived as a transversal (tJP) one, forming in this way a new concept to be later addressed by new initiatives if needed. The final outcome is the launch of this transversal Joint Programme ‘Digitalization for Energy’ (tJP DfE), which aims to define key priorities for DfE that will derive in research activities as well as act as contact point with major European initiatives on supercomputing, big data, artificial intelligence, open science, etc. Now is a very suitable time to launch this new tJP, following the European Digital Strategy which is strongly pushing these IT services.

This tJP is launched with a modular structure, i.e. integrating ongoing EERA initiatives (and keeping their structure as SPs) to the specific SPs to this tJP focused on digital activities, in a transparent and agnostic way. By doing so, it will be straightforward to integrate new SPs and features coming from either vertical JPs, as they also evolve in time, or coming from the tJP itself.

Regarding the management of the tJP, it refers to a lightweight cross-cutting tJP with only one JP Coordinator, a Deputy, and the Management Board (MB), which is designed as a forum where there are already activities from the beginning and new ones will be designed and planned. The Steering Committee is constituted by the EERA President, Vice-President(s) and Secretary General ([see below for the definition of this structure](#))

Different thematic areas of focus are set out in six (6) SPs of this tJP DfE. The list as that of October 2020 is:

- Specific SPs belonging to this tJP
  - SP1 HPC
  - SP2 Data Science & Artificial Intelligence
- ESI tSP “Technology”
- AMPEA tSP “Multiscale modelling of materials, processes and devices”
- Hydropower tSP “Digitalization”
- Nuclear Materials tSP “Physical modelling, materials health monitoring and non-destructive microstructure examination for nuclear materials”

These SPs jointly with the MB will pursue the different technical and non-technical objectives described in this document below.



## 2 Introduction

In 2019, Ms Ursula von der Leyen, President of the European Commission, has acknowledged the climate emergency and has promoted the Clean Energy Transition (CET, also named in the agreement ‘Clean energy for all Europeans package’) as the political priority for the Energy Union strategy. The recently announced European Green Deal will support the ambition of a fair transition for the EU to a climate neutral society by 2050, which will soon be enshrined into the most progressive legal framework for delivering on the EU’s Paris agreement to date and places special emphasis on those sectors that produce more emissions such as transport, energy or industry.

In this way, the CET Partnership is intended to intensify and better leverage public and private investments and to create trans-national integration in thematic areas of joint interest within the European Research Area on this crucial process. To do so, the new instruments proposed by the upcoming Horizon Europe Framework Programme (HEU) will be of great importance. This proposed co-funded partnership will build on work already carried out in the Strategic Energy Technology (SET)-Plan, i.e. the definition of common targets and the creation of Implementation Plans (IPs) endorsed by the Member States and Associated Countries (MS/AC), integrating existing support into a larger, and more efficient and ambitious system.

In this context, The European Energy Research Alliance (EERA), which is the Research Pillar of the SET plan and a cornerstone of joint research efforts across MS/ACs, is in a unique position to advice on the Strategic Research and Innovation Agenda (SRIA) that should guide the CET Partnership investments. In addition, it is worth mentioning that relevant European long term policies and strategies are also cornerstone to EERA and are then much promoted beyond HEU and the CET Partnership themselves.

Recently, EERA has revised its Mission into “catalysing European energy research to achieve a climate neutral society by 2050”, an aim that is strongly embedded within the SRIA and summarized in Fig. 1.

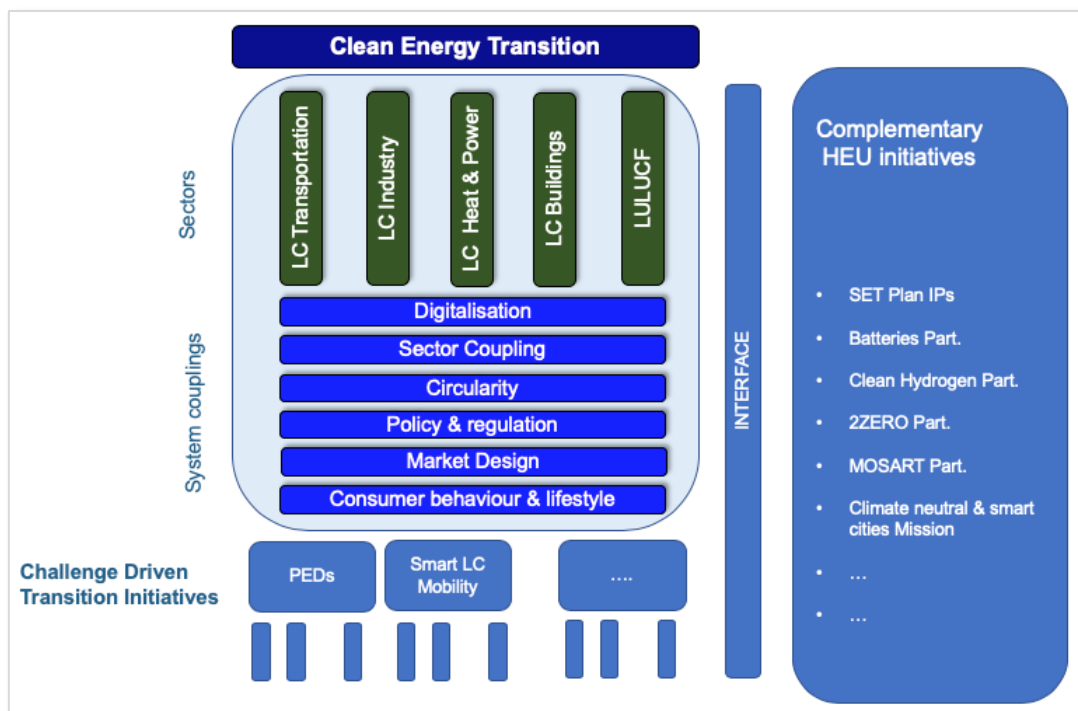

Figure 1: Conceptual framework defining the Clean Energy Transition

It is stated in the SRIA that the CET should provide enough flexibility to accommodate the evolution of requirements over the seven years of the partnership's lifetime, and recognise the evolution of boundaries from other initiatives and programmes. EERA, therefore, proposes to define the SRIA at the level of the "Challenge Driven Transition Initiatives"<sup>1</sup> that will embed this level of flexibility, while ensuring that the nature of the societal challenge and its targeted impacts are met. In this context, digitalization is identified as one of the technologies and initiatives that will enable this challenge-driven transition. It is also part of initiatives within the IEA<sup>2</sup> and, obviously, the European Commission<sup>3</sup>.

The topics related to digitalization mentioned in the SRIA cover a wide set of activities. Thus, the increasing use of modern computer science techniques, not only High-Performance Computing (HPC), but also and especially the ability to analyse large amounts of data (Big Data) using machine-learning algorithms, particularly Artificial Intelligence (AI) in all its forms, have an impact on energy technology, both directly or indirectly. In this sense, data-driven continuum simulations will be cornerstone in several energy domains as defined in the EERA strategic long-term scenario.

On-line monitoring and digital twins allow the performance of key components and sub-systems to be optimized, with subsequent reduction of cost, increased efficiency and safety, and optimised management of inspections and replacement, with an impact on increased component lifetime and therefore reduction of waste. Likewise, the combination of HPC, automated fabrication and characterization (robotics and AI), advanced modelling, and data-analysis (data-driven-modelling) allow for enhancements in energy production and in usage by the end-user. Some examples could be the acceleration of materials development to be achieved, network coupling, automated systems, etc. A trend of edge processing is emerging in the energy sector where much of the data processing is decentralized close to the data source and a limited amount of data is passed back to a central control unit. This development could enhance resilience in the system as autonomy in dispersed systems may be achieved.

However, the extensive and generalized use of digital techniques exposes the energy system to a new class of vulnerabilities and highlights the problem of guaranteeing cybersecurity and cyber-robustness of the energy system or of (economic) transactions related to the energy sector, just to mention a few.

As a result, digitalization impacts strongly on most of the activities that have been carried out by EERA, already articulated through their Joint Programmes and, consequently, within the CET. Hence, digitalization should be perceived as an opportunity and an 'enabler' that will connect Energy technologies in a cross-cutting and holistic fashion.

Advanced digitalization can be enhanced by changing the way in which research is being done providing new results, impact, revenue, and value-producing opportunities, a fact that will have a positive impact in EERA's community practices.

## 2.1 Background

EERA already covers the whole range of low-carbon energy technologies while also addressing systemic and sustainability related topics. Nevertheless, in a technological world heavily reliant on IT know-how, EERA still lacks a JP focused on cross-cutting advanced IT fields. A huge effort on digitization has been accomplished by moving from analogue to digital technology.

There is a plethora of activities in which advanced IT services are used in the energy sector. Supercomputing simulations related to weather forecasting, design of turbines in off- and on-shore wind energy production, molecular dynamics, ab initio calculi in the study of the

---

<sup>1</sup> As that of Feb 2020, there are ten (10) proposed "Challenge-Driven Transition Initiatives", being one of those Digitalization. The reader can consult the EERA strategic long-term scenario for further details

<sup>2</sup> <https://www.iea.org/digital/>

<sup>3</sup> <https://setis.ec.europa.eu/setis-reports/setis-magazine/digitalisation-of-energy-sector>

interaction of the media on structural and functional materials, new advanced materials and processes, integrated energy system analysis, energy mix composition and further distribution in the electricity grid, are just a few examples of simulations already essential today. Likewise, in the era of the big data, there are huge amounts of data stored in many formats and repositories by the EERA communities that need to be properly exploited in terms of standardisation and information that can be deduced from them with artificial intelligence methodologies. The same can be said about open access regarding publications.

While the amount and extent of data (including complexity and heterogeneity) are immensely growing, novel approaches for data stewardship need to be developed and put into practice. Indeed, researchers spent a rapidly growing amount of time for finding, cleaning, and checking of data. Therefore, the definition of data standards, the creation of an ecosystem of skills and cultures for FAIR and open data, and incentives to embed and sustain the same are urgently needed. In addition to this, trust mechanisms and technological solutions to guarantee data privacy, security and sovereignty should be developed.

Data assimilation is also a must. Internet of things, smart meters, and the increased deployment of advanced on-line sensors are other areas in which IT services are producing data on-the-fly that are cornerstone in major energy facilities, electricity market with new types of actors, etc. EERA community ought to take advantage of this new data throughput and computing capacity for decision-making processes, for example.

New paradigms such as blockchain technologies (an open, distributed ledger that can record transactions between two parties efficiently and in a verifiable and permanent way) are key in sectors such as accountings of the energy storage usage or as digital twins (a digital replica of a living or non-living physical environment). , allowing the behaviour of a system to be modelled to better understand and predict its performance, as well as its potential failures. This representation can be through a model that we call physical, data or hybrids.)These technologies support improvements in the operations of major energy platforms and can become positive outbreaks in the energy sector.

Alongside with the ongoing data revolution in the energy system, the energy market is in transition. We see an overall increase in complexity. New actors with diverse objectives are entering the market, extending the number and type of participants beyond business utilities and other incumbents. The increased complexity drives the need for advanced tools to make optimal decisions and support evidence-based policymaking and monitoring. At the same time, energy businesses transit towards digital twinning, equipment monitoring, as well as digital reporting and compliance checks.

Also, the market experiencing every shorter time-constant in its operation and the overall lifecycle, and there is a need for digitalization and automatization in order to handle this development. The presence of an efficient a fair marketplace for energy is essential for the CET, and relies heavily on a deep and successful digitalization of the energy sector..

Europe is strongly fostering the implementation of advanced IT services by means of own developed technology, in a way in which co-design is a cornerstone, i.e. emerging computational infrastructures are being designed taking into account applications and code requirements. The EuroHPC Joint Undertaking<sup>4</sup>, the European Processor Initiative<sup>5</sup>, or the EoCoE-II<sup>6</sup> and the EERAdat<sup>7</sup> projects are good examples of this. Also, European technology platforms such as ETP4HPC<sup>8</sup> or BDVA<sup>9</sup> can be cited.

---

<sup>4</sup> <https://eurohpc-ju.europa.eu/>

<sup>5</sup> <https://www.european-processor-initiative.eu/>

<sup>6</sup> <https://www.eocoe.eu/>

<sup>7</sup> <https://eeradata-project.eu/>

<sup>8</sup> <https://www.etp4hpc.eu/>

<sup>9</sup> <http://www.bdva.eu/>



Under this scenario, it is a clear asset to count on a JP capitalizing the related EERA interests and priorities in order to improve the value chain in the energy sector carrying out specific research on the targeted topics, provide an important reference point for the EU research agenda, and ensure a better coordination with ongoing and future initiatives coming from the IT world.

In order to maximize the impact of digitalization as a cross-cutting activity within EERA, this new Joint Programme (JP) is conceived as a transversal (tJP) one, forming in this way a new concept to be later addressed by new initiatives if needed. Such a fact is expected to be a strength of this tJP within EERA.

## 2.2 Strategic Leadership and added-value

Digitalisation is an inherent technology to almost all developments that are being carried out within the energy field, playing the part as either the key actor or as a supporting measure that enhances the results of the main activity. With this in mind, EERA aims to play a leading role within the CET by identifying those specific developments where digitalisation is crucial to the sector and build synergies among the vertical and traditionally ongoing JPs. This is crucial in order to retain EERA's leading role within the energy field, and to fend off competition from other actors.

As a consequence, it is expected that a major R&D investment into integrating efforts and activities will be initiated, which will enhance and enable networking within the EERA community working whose work relate to digitalization. Such an investment will rest on the advantage that is specific to the field of digitalization. In this regard, developments designed and implemented through digital means would be much valuable if they can be applied to different scientific-technological fields, even if the digital technologies have to be customized for their specific usage. A general example could be today's large high performance computing (HPC) clusters, used to support research on wind, materials, system integration, smart cities, etc., while there is also a plethora of techniques, methodologies, and ideas rising from digitalization that are fully multidisciplinary.

Further, the investment in digitalisation also aims to integrate and coordinate efforts deriving from initiatives outside EERA that play a very significant role in digitalization and funding, both from the public and private sectors as per below.

Several EERA activities clearly demand digital services based on:

- High Performance Computing (HPC)
  - Weather forecast or turbines in off-and on-shore wind energy
  - Molecular dynamics or ab initio calculi in the study of the interaction of the media on structural and functional materials, new advanced materials and processes
  - Integrated energy system analysis, energy mix and further distribution in the electricity grid
  - Design of new devices such as turbines, solar thermal plants, collectors, etc.
  - CFD analysis of heat transfer between solar radiation, materials, and fluids
  - Multiscale simulations
  - Economic energy models
  - Etc.
- Data Science
  - Standardisation of data and metadata within many JPs
  - Harvesting, curation, checking and exploitation of data
  - Data security, privacy and sovereignty requirements and algorithms
  - Artificial intelligence methodologies
  - Open Access and FAIR principles
- High Throughput Computing (HTC)

- Data assimilation (Internet of things, smart meters, and sensor deployment)
- Edge and Fog Computing (Smart Cities, major energy facilities)
- New actors in a distributed electricity market (ESI, for example)
- New paradigms and platforms
  - Blockchain (energy market, for example)
  - Digital twins (NM, major energy facilities)
  - Digital platforms

Behind all the previous items, there is a solid track of research that forms the foundations of this new JP. Some examples are:

- Design of Digitalized Intelligent Energy Systems, for example, their application to cities in which zero emissions buildings or intelligent power systems are pursued
- Deeper understanding of the physics behind the energy sources, for example, multiscale simulation or of the atmospheric flow for wind farm operation through CFD–RANS or LES simulation coupled to mesoscale models taking advantage of the capabilities offered by exascale computing.
- New designs of Fluids Structure Interactions (FSI), for example, for full rotor simulations coupled to CFD simulations.
- Structural dynamics (fatigue) in different devices, which affects almost every JP
- Designs of customised machine and deep learning techniques
- Optimization of codes by the means on new mathematical kernels, not simply computational porting
- Market prediction based on data-driven methodology sourcing on-line data from multiple domains
- System stability assessments and early warning systems for power systems with a large number of distributed sensors enabling deployment of mitigating actions
- Integration of different computing platforms seamlessly combining HPC, HTC, and High Performance Data Analytics methodologies
- Efficient implementation of digital platforms

All of these examples have to result in technology transfer to the industry beyond the benefits achieved by the groups working on these and other topics and are beyond typical support activities in which simply a computing platform or general method is used. Examples of this include the execution of codes on exascale supercomputers or the application of neural networks designed as part of Tensor Google.

In order to evaluate the interest within EERA in digitalization aspects, a first survey was carried out in 2018. The survey found that at least 10 out of the 17 running JPs rely on simulation techniques, repositories management and curation, sensorization, digitization, digital twins, computational techniques, artificial intelligence methodologies, energy system modelling and analysis, etc. In particular, the following JPs showed an interest:

- Advanced Materials and Processes for Energy Application
- Concentrated Solar Power
- Economic, Environmental and Social Impacts
- Energy Systems Integration
- Fuel Cells and Hydrogen
- Geothermal
- Nuclear Materials
- Photovoltaic Solar Energy
- Smart Grids
- Wind Energy

Their interest was scored with an average of 7 over 10 (for the sake of completion, 7 JPs scored that interest with a higher mark) and 7 JPs declared to count on in-house digital expertise (HPC or Big data, for example).

In 2020 a new questionnaire was sent out in attempt to capture and assess the interests for this tJP among the running JPs. Aspects that were scored numerically were: the interest in this tJP; relevance of initial topics to be addressed on HPC, Big Data (BD), and Artificial Intelligence (AI); consideration for integrating ongoing sub-programmes to be “shared” within the tJP; and, endorsement for the creation of the proposed tJP. Additionally, respondents were asked elaborate on other topics that should be covered and the identification of potential strengths and weaknesses.

The survey collected 20 full answers from 11 JPs; these were:

- Advanced Materials and Processes for Energy Application
- Bioenergy
- Economic, Environmental and Social Impacts
- Energy Systems Integration
- Fuel Cells and Hydrogen
- Geothermal
- Hydropower
- Nuclear Materials
- Photovoltaic Solar Energy
- Smart Grids
- Wind Energy

Scores for the first questions varied from 3.67 and 4.17 over 5 and interesting answers for the rest of the survey were written down and presented to the EERA Executive Committee and the JP coordinators.

The final outcome of this internal EERA process is the launch of this transversal Joint Programme Digitalization for Energy (tJP DfE) taking into account the inputs provided, i.e. the organization of a centralised JP defining key priorities for DfE as well as acting as contact point with major European initiatives on HPC, BD, European Open Science Cloud<sup>10</sup> (EOSC), etc. Now is a very suitable time to launch this new tJP, following the European Digital Strategy<sup>11</sup> which is strongly pushing these IT services.

Some of the strengths that would rise from the launch of this tJP and produce the pursued R&D investment are summarized below:

- Reinforcement of the EERA position in Europe in topics related to DfE
- Performing of cross-cutting research activities that can be only achieved by close collaboration of scientists and researchers from the energy and digitalization sectors
- Internal coordination and integration of EERA JPs’ interests related to DfE, avoiding duplicated efforts and profiting from lessons learnt (some of the solutions are usually of application to several domains)
- Coordination and collaboration with external initiatives focused on developing digitalization activities in order to put the energy sector on board as ‘major use case’
- Collaboration with the HEU managerial structure for advocacy related to joint energy–digitalization interests to be included in future work programmes
- Stronger liaison with industry on digitalization, acting as a first point of contact
- Networking during events focussing on the use of digital technologies in support of CET.

Of course, some weaknesses have been identified and the tJP must properly work to overcome them: potential disconnection and time spent to provide solutions; duplicity; lack of critical mass if similar efforts are not joined, but dispersed... These issues are addressed in the Risks section.

---

<sup>10</sup> <https://www.eosc-portal.eu/>

<sup>11</sup> <https://ec.europa.eu/digital-single-market/en/content/european-digital-strategy>

As digitalization is reinforcing every activity in our society in one way or the other, EERA cannot omit such a trend and based on the above mentioned arguments it should launch a tJP DfE. In this way, EERA will reinforce its leadership in energy research, and remain in the forefront of defining and planning the objectives and activities to be carried out in the coming years. This tJP will enforce EERA's leadership by compiling and collating ongoing efforts to optimise them and develop cross-cutting activities that will be leveraged by the EERA community.

Thus, internally, such an investment will be the added value of this tJP. With respect to external priorities, EERA will coordinate activities through this tJP with external major initiatives and entities working on digitalization, assuring that EERA retains its leading position within energy R&D while fending off competition.

## 2.3 Objectives

In an evolving world in which digitalization is continuously providing new features and capabilities, the tJP DfE objectives must be articulated in a modular way (see below). Thus, identified objectives ought to be defined in a two-fold basis. On one side, non-technical and permanent objectives must be identified for consolidating the tJP both within EERA and outside; on the other side, technical objectives should be revised in a periodically updated SRIA. Above all of this, a connection with the other end of digitalisation must be put in place, i.e. digital methodologies and techniques will be finally used for achieving new results in different energy sectors.

Among the former non-technical objectives, the following are proposed:

- To support EERA and the JPs to agree on key research priorities regarding how energy research and technology could profit from advanced IT services, promoting and developing in this way cross-cutting activities
- To facilitate and boost the achievement of new results in different energy sectors by means of the digital solutions provided within the tJP
- To get allocation of computational, storage and, advanced IT services and resources from different initiatives such as EuroHPC
- To advance in the development of community standards for FAIR (Findability, Accessibility, Interoperability, and Reusability) and open data
- To set up a fluent communication and exchange of information with the European Commission and major IT-related European initiatives outside EERA (EuroHPC, EOSC, BDVA, etc.) in order to
  - design calls as part of Horizon Europe and other funding programmes
  - build up synergies
  - access to Pan-European IT infrastructures such as PRACE<sup>12</sup>/EuroHPC, EOSC
- To exchange information and feedback from the IT European industry and Technology and Innovation Platforms in order to reinforce future developments within the Alliance and increase TRL of funded projects
- To promote EERA and the tJP itself via dissemination, networking, and outreach activities

Several general activities will be put in place to enhance the impact of the tJP with respect to the technical objectives:

- To complete a map of numerical codes and databases
- To pursue the allocation of advanced digital resources for their exploitation by the tJP community

---

<sup>12</sup> <https://prace-ri.eu/>

- To produce added value reports profiting from a permanent contact with the rest of JPs
- To gather regularly the EERA community in workshops and meetings to ensure a continuous exchange of knowledge
- To promote student exchange and research visits
- To organize “Hands-on” and “Hackathon” type meetings
- To disseminate vacancies and opportunities between the tJP community

In addition to the previous non-technical objectives, the specific objectives defined by the SPs will be integrated in the previous list in a way that their potential outcomes will be transferable to other JPs. This way, the specific results spanning from the existing SPs will not be the targets of this tJP. Instead, the targets of this tJP will be the digital methodologies and techniques used for achieving such results.

## 2.4 tJP Structure

The tJP DfE addresses a new paradigm in which direction EERA might move in the coming future, i.e. approaching cross-cutting activities. Such a paradigm stems from the logic evolution of how the multidisciplinary science is being carried out presently. Thus, it aims to create a clear added-value for EERA members and to avoid the creation of new layers. Also, on the basis of this experience, in the future other tJPs might be designed and the EERA structure progressively adapted.

A clear and timely example of cross-cutting activity is digitalization, and that is why this tJP is launched with a modular structure, i.e. integrating ongoing EERA initiatives (and keeping their structure as SPs) to the specific SPs to this tJP focused on digital activities, in a transparent and agnostic way (see Fig. 2). By doing so, it will be straightforward to integrate new SPs and features coming from either vertical JPs, as they also evolve in time, or coming from the tJP itself.

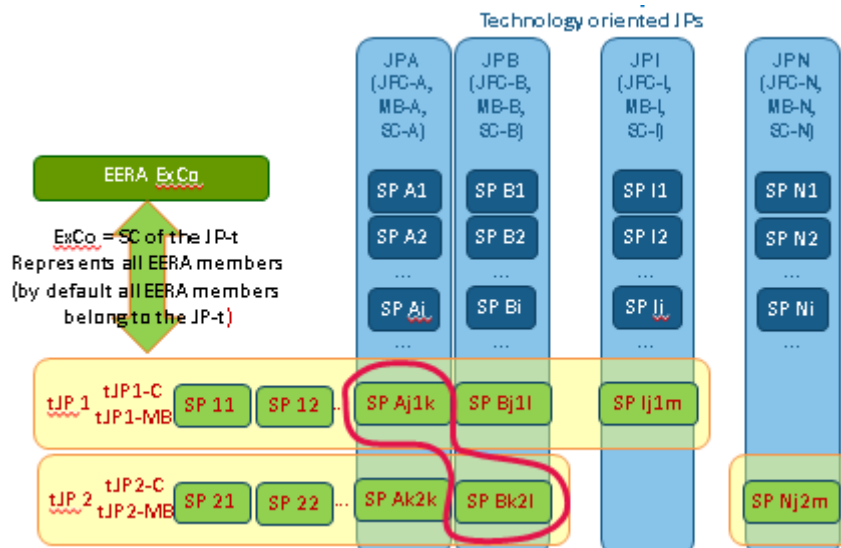

Figure 2: Conceptual framework for defining the tJP structure.

Then, for defining the structure, a first step has been the identification of cross-cutting and systemic issues on Digitalization in the ongoing JPs. A second step has been the identification of SPs where the cross-cutting/systemic topic is explicitly addressed for the specific technology in each concerned JP. The third and last step has been the identification of the SPs that would directly come from the tJP and the activities they would carry out.

Regarding the management of the tJP, it is described in detail below, but it is worth noting that it refers to a lightweight cross-cutting tJP with only one JP Coordinator, a Deputy, and the Management Board, which is designed as a forum where there are already activities from the beginning and new ones will be designed and planned.

Different thematic areas of focus are set out in six (6) SPs of this tJP DfE, which will be explained in detail below in chapter 3. The SPs as those of October 2020 are:

- Specific SPs belonging to this tJP
  - SP1 HPC
  - SP2 Data Science & Artificial Intelligence
- ESI tSP “Technology”
- AMPEA tSP “Multiscale modelling of materials, processes and devices”
- Hydropower tSP “Digitalization”
- Nuclear Materials tSP “Physical modelling, materials health monitoring and non-destructive microstructure examination for nuclear materials”

For the sake of completion, the final structure is depicted in Fig. 3.

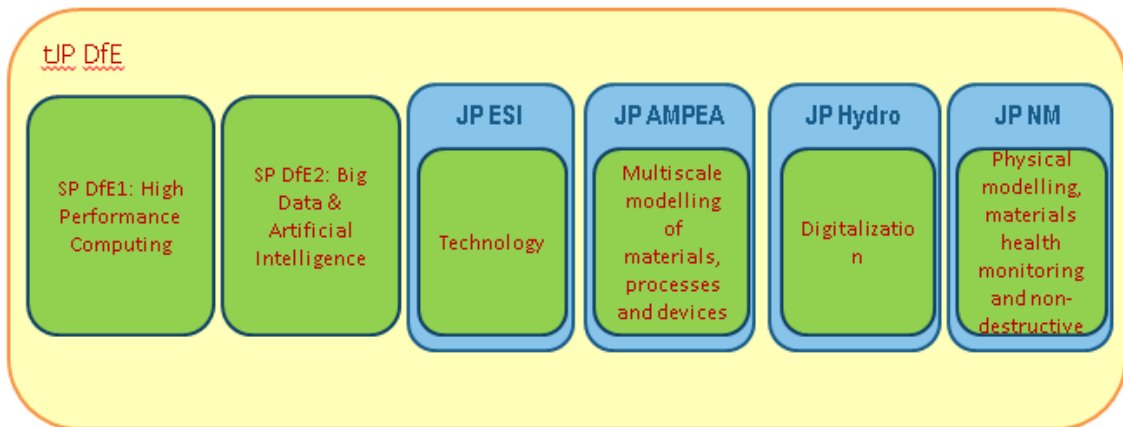

Figure 3: Structure of the tJP on DfE.

## 3 Overview of Sub-programmes

In what follows, a description of the SPs participating in this tJP follows. Those already belonging to vertical JPs count on a detailed explanation in their respective 'description of work' and SRIAs, so a more focused and brief description on digitalization activities is included here.

All of them list the background in which they plan to carry out their activities, the pursued objectives, the identified topics, the expected outcomes, and the main contacts' information.

### 3.1 SP1 – HPC

It is becoming increasingly apparent that the future energy ecosystem will rely heavily on digitization to drive essential innovations in production and storage technologies, mitigate power source variability, and manage its distribution via a complex hierarchy of micro- and macro-networks. One of the main parts in which this digitalization can be achieved is by linking together through a multi-disciplinary platform of high performance computing (HPC) and numerical mathematics a network of experts in computational and energy sciences. The drive towards exascale computing over the next 5 years will enable significant step changes in the predictability and management of renewables as their share of the energy mix increases towards 100% over the coming decades.

In this sense, it is important to highlight that the work done and the know-how developed for designing, implementing, and executing an application simulating an energy source or process can then be leverage for other applications. Even more, these codes are all used in the energy domain and will therefore contribute to the European Energy transition, being at the same time a clear example of cross-cutting activity and outcome within this tJP.

#### 3.1.1 Background

The new possibilities in Energy Science opened by exascale computing have potential benefits for both fundamental research and industrial competitiveness alike, but which will only be achieved by investing effort to master the many-core/accelerator technologies set to dominate the HPC landscape in the near- to mid-term. Many developers are essentially domain scientists who do not have the required computer science background to redesign, implement, maintain high-end reusable software. Conversely, codes developed by HPC specialists often do not meet the needs or the expectations of end-users, especially in the R&D domain where scientists need to have a deep knowledge of the physical model implementation in order to verify that the codes reproduce well documented scenarios and place a high level of confidence on the outcome of hitherto unexplored regimes.

In order to overcome these mismatches in expectations and approach, this SP will work on enforcing multidisciplinary teams devoted to pool the required skills from HPC engineers, applied mathematicians, and application domain specialists. These teams are expected to work together over an extended period to develop application software that is both science-driven and (exascale) HPC enabled. Thus, some of the main technical Challenges that have been identified and will drive this SP are:

- Programming Models for handling efficiently complex computing nodes having a deep memory hierarchy and possibly accelerators, addressing more operation concurrencies, and minimizing development effort that maximizes performance portability
- Scalable Solvers and algorithmic issues strongly linked to linear algebra for refactoring existing solver packages to reach Exascale. New algorithms are necessary to reach the required level of scalability.

- Input/Output (I/O) process and data flow for leveraging efficiently the capacities of the coming hardware that will further extend the deepness of the memory hierarchy (NVRAM, SSD...) in order to write and read large amounts of data to/from the parallel file system.
- Ensemble runs, simulation ensembles, and more generally workflows that include potentially data assimilation for the integration of software technologies to run efficiently on coming pre-exascale and exascale systems, The objective pursued here is to provide a flexible and maintainable way of executing simulation ensembles in multiple jobs on a given supercomputer while enabling communication between ensemble members to allow ensemble management and data assimilation processes.

Joining all these technical challenges represents a flexible approach that embraces I/O, ensemble run, and programming model in order to contribute to the necessary paradigm shift. Not only this, it aims modularity, maintainability, and adaptability to new coming hardware, allowing in this way integrating additional capabilities such as in-situ or in-transit post-processing, fault tolerance mechanisms, etc.

Ongoing projects such as EoCoE-II<sup>13</sup>, Enerxico<sup>14</sup>, POP<sup>15</sup> or MAX<sup>16</sup> are funded initiatives that are contributing to the previous challenges.

### 3.1.2 Objective

The complexity level that exascale computing brings poses a set of technical challenges for the numerical modelling, algorithmic kernels, and computer science areas. Design and implement efficient applications that will fully exploit exascale supercomputers must take into account all of them under a common view, i.e. the so-called co-design strategy. Thus, future codes and applications will have to balance data transport and compute capabilities, make use of task-based programming models and memory hierarchies to cope with forthcoming hardware architectures, and be able to mitigate the increase of run-time errors associated with extreme parallelism. At the same time, they will need to remain relevant to their communities in order to maximize their impact, attract interest from users outside the own developing group, and engage energy industrials and SMEs.

This SP will be guided by the following three high-level objectives with the goal of designing new Energy oriented Scientific Challenges that could exploit the next generation of exascale supercomputers. Technical Challenges and advanced HPC services will be the key tools to accelerate the Scientific Challenges implementation and create a new community of experts, that will be able to address energy open problems by taking advantage efficiently of the new advancements in HPC, ICT and numerical modelling sectors.

#### Enable transformational Energy Science via HPC

##### **Task 1.1** Enable transformational Energy Science via exascale application codes

The underlying objective is to enable transformational Energy Science breakthroughs in low-carbon sectors of interest to EERA by re-designing and promoting (pre-)exascale application codes from their user communities.

In this sense, it will be of usefulness to identify scientific challenges based on flagship applications, which will be of scientific relevance and will provide a first path for testing new computational methodologies that will be lately transferred to a wider set of applications.

---

<sup>13</sup> <https://www.eocoe.eu/>

<sup>14</sup> <https://enerxico-project.eu/>

<sup>15</sup> <https://pop-coe.eu/>

<sup>16</sup> <http://www.max-centre.eu/>



Such a redesign of applications will allow EERA becoming a large user of HPC resources in Europe and, consequently, a major actor in European computational science.

Several general lines of research and activities have to be developed for obtaining efficient application codes that will be able to fully exploit the coming exascale supercomputers. On one side, cutting-edge mathematical, numerical, and computational methods as well as software technologies have to be developed and improved in order to remove bottlenecks in flagship scientific applications and to anticipate future needs (the third ETP4HPC Strategic Research Agenda (SRA3) white paper has comprehensively documented and examined expected general bottlenecks on forthcoming computing architectures <sup>17</sup>). This is mandatory to maintain state-of-the-art numerical tools on coming pre-exascale and exascale supercomputing infrastructures while ensuring the capability to make scientific progress along the transformational Energy Science.

*Objectives:* Design and implementation of Scientific Challenges of interest to the involved JPs. To this end, identification of flagship codes, companion codes, state-of-the-art in those JPs, bottlenecks, costs, synergies among different JP applications, gap analysis, etc. will be carried out. Design of demonstrators will be developed too.

**Task 1.2.** Design and develop cutting edge computational methods and production ready HPC software to bring the scientific numerical tools to Exascale computing levels and manage the data generated.

On the other side, teams composed of HPC experts, applied mathematicians, and domain scientists have to join efforts to foster and implement an integrated co-design approach for the development of exascale applications. In order to use increasingly complex exascale architectures, new HPC paradigms will be developed in strong interaction with domain scientists. This interaction will be hard-wired into this SP with the final objective of identification of Technical Challenges needed for the energy sector. New programming models, scalable solvers, I/O data flow, ensemble runs are example of Technological Challenges that will be addressed.

There are specific developments to be achieved that have been identified within the SP:

- Programming models will be focused on how to handle efficiently complex computing nodes having a deep memory hierarchy and possibly accelerators. Also, how to address more operation concurrencies and to minimize development effort that maximizes performance portability. In this sense, it will be useful to benefit from existing developments and to stick to established standards or emerging technologies like task-based programming models
- Scalable Solvers will be focused on algorithmic issues that are strongly linked to linear algebra. Refactoring existing solver packages will not be enough to reach Exascale. New algorithms are necessary to reach the required level of scalability in a way in which, depending on the type of problem to solve, a hybrid solution between software and/or algorithmic approach will be put in place.
- I/O & Data Flow will be focused on leveraging efficiently the capacities of the coming hardware that will further extend the deepness of the memory hierarchy (NVRAM, SSD...). Efficiently writing large amounts of data to the parallel file system will be an asset, but deep memory hierarchies call for paradigm shift in the way fault tolerance is handled and postprocessing is implemented with in-situ and in-transit capabilities will be tackled as well.
- Ensemble Runs will be focused on the integration of software technologies to run efficiently on coming pre-exascale and exascale systems, simulation ensembles and

---

<sup>17</sup> <http://www.etp4hpc.eu/sra-2017.html>

more generally workflows that include potentially data assimilation. The objective pursued here is to provide a flexible and maintainable way of executing simulation ensembles in multiple jobs on a given supercomputer while enabling communication between ensemble members to allow ensemble management and data assimilation processes.

#### Promote high-end exascale services

**Task 1.3.** Promotion of a co-design software development approach and the use of numerical tools to energy communities

As a hub in the HPC/simulation for energy domain, this SP will disseminate the knowledge and advances obtained in this field providing not only high-end exascale codes for selected, high-impact applications areas, but also a set of techniques and expertise that will be able to be transferred to other applications and domains, achieving in this way real cross-cutting advances.

It is planned to design a Software-as-a-Service (SaaS) portal to attract both internal and external EERA communities in which the different advances will be listed to foster new collaborations and provide consultancy and expertise to these laboratories. The SaaS portal will be also used as software repository and as service provider.

Might it be awarded, the access to advanced HPC infrastructures such as EuroHPC will facilitate the end-user access to HPC capabilities, including the software packages and tools. This kind of federated HPC infrastructure would provide HPC services based on a shared agreement and appropriate planning and allocation of resources. The main objective would be to design and implement a seamless access to HPC distributed infrastructure.

Specific actions devoted to the organization of conferences and workshops as well as education and trainings events (jointly with initiatives such as those coming from the PRACE Advanced Training Centres) will be carried out jointly with the SP “Data Science and Artificial Intelligence”. The final goal is then to develop a large network to promote the tools and best practices as well as gather needs through a tight collaboration with EERA.

*Objectives:* Design of a SaaS portal as main entrance to HPC service of EERA.

*Conceptual models:* Balance computing and programing models; I/O, data flow, and storage Performance; Mathematics, solvers, and algorithms for extreme-scale HPC systems; Ensemble runs and workflows; Quantum mechanics; Ab-initio methods; Molecular modelling; Fluidodynamics; Monte-Carlo methods; Finite volume method; Finite element method

*Numerical models:* LAMMPS, Quantum Espresso, QMC, Metawalls, ALYA, ParFlow, Parallel Data Interface (PDI), Melissa.

### 3.1.3 Identified topics and expected output

Topic	Expected output	by	Expected deliverables
Scientific Challenges	Assessment of the JPs computational activities and identification of their scientific priorities and synergies	2021	Report on the design of Scientific Challenges (public)

Technical Challenges	Identification of HPC tools and service of interest for the energy communities	2021	Report on the use of HPC tools and gap analysis (public)
HPC developments for Energy	Position paper elaborated from the collaboration between EERA and EoCoE-2.	2021	Report (public)
SaaS portal	Design and implementation of the SaaS portal: services and codes	2022	SaaS portal implementation
Energy oriented HPC community	Build a large European community to coordinate the deployment of HPC for energy and to foster challenging initiatives	2023	Report on HPC for energy community: vision, initiatives and future plans (public)

Table I: Identified topics and expected output for the HPC SP

### 3.1.4 Contacts

<i>Company name</i>	Commissariat à l'énergie atomique et aux énergies alternatives (CEA)
<i>Contact person</i>	Edouard Audit
<i>Postal address</i>	Maison de la Simulation DigitéoLabs, Bât 565, CEA-Saclay 91191 Gif-sur-Yvette Cedex
<i>Country</i>	France
<i>E-mail</i>	edouard.audit@cea.fr
<i>Telephone</i>	+33 1 69 08 96 35

Table II: Identified contacts for the HPC SP

## 3.2 SP2 – Data Science & Artificial intelligence

### 3.2.1 Background

With the advancement of digitalization in all areas of energy research, large amounts of data are generated every day offering new and innovative ways to optimize energy supply and demand and to steer the transition to a more sustainable energy system. Artificial intelligence tools and algorithms offer a unique possibility to support the analysis of the data and automatize many processes. However, the lack of standards for data storage, processing, and quality is severely limiting these options. The majority of databases and repositories are unfit for deploying advanced analytic tools by humans as well as machines. Also, the decarbonisation of the economy thorough the development of, sustainable energy systems requires the integration of interdisciplinary and complex data. It means that it is not sufficient to only account for physical and technical attributes, but also for socio-economic and environmental ones. Otherwise, the society will be misinformed about the consequences of the upcoming fundamental systemic changes, affecting the building of acceptance for the energy transition and creation of ownership over the same. Thus, a transparent and integrated management of energy data with useful metadata information and quality assurance provides the basis for the society to choose monitor and implement sustainable transition pathways. All data should be as open as possible but acknowledge that data may have to be modified or made less open if there are commercial, security, privacy or consumer impact issues that need

to be mitigated. The required trust mechanisms and technological solutions to guarantee data privacy, security and sovereignty should be developed. A necessity on building on significant gains in our knowledge over the past decades on data management, to contribute to defragmenting data flows across topics, time and space.

A way forward is the implementation of FAIR principles, where FAIR stands for F-findable, A-accessible, I-interoperable, R-reusable<sup>18</sup>. In order to integrate these principles into the workflow of energy data managers, producers, and users, we need to build capacities to support the development of data governance infrastructure. The process of establishing the support for the FAIRification and opening of energy data starts with the definition of domain-specific metadata standards and does not end with solving issues around the certification and licensing of data<sup>19</sup>. The tasks listed below describe areas of action. Hereby, synergies with the ongoing EU-project EERAdata “Towards a FAIR and open data ecosystem in the low carbon energy research community (03/2020-02/2022)” will be used.

On the other side, the advent of this huge amount of data has also brought the challenge of how to properly extract information from them. First successful attempts came with the methodologies and ideas applied by the Big Data paradigm, with techniques such as MapReduce, High Performance Data Analytics, High Distributed File Systems, etc.

Nowadays, a major step forward has been taken with the application of Artificial Intelligence (AI) in addition to the more used ‘traditional’ stochastic processes. Central to AI is that it makes and implements decisions based on data (information) independently with regard to the set goals, so AI has been adopted by both the energy industry and research sectors.

AI has become more and more important in the energy industry and is having great potential for the future design of the energy system. Typical areas of application are electricity trading, smart grids, or the sector coupling of electricity, heat and transport. Prerequisites for an increased use of AI in the energy system are the digitization of the energy sector and a correspondingly large set of data that is evaluable. AI helps make the energy industry more efficient and secure by analysing and evaluating the data volumes.

The growth of installed renewable energy generation capacity has triggered a paradigm shift in the energy industry with a move from traditional baseload power generation sources of coal and nuclear energy to the now lower cost renewable energy resources of wind and solar power. However, this fundamental shift has widespread consequences in the energy industry, as traditional baseload generation is less variable due to weather dependence than renewable energy resources that are fundamentally driven by the weather. Additionally, the industry is changing from a market based on commodity pricing to a market based on technology solutions in order to integrate renewable energy. As the energy industry continues to utilize more variable and geographically distributed generation sources, accurate forecasts of power generation and net load are becoming essential to maintain system reliability, minimize carbon emissions, and maximize renewable energy resources.

AI approaches are being developed to produce more accurate predictions of renewable energy, including their generation and impacts on the electric grid such as net load forecasting, line loss predictions, maintaining system reliability, integrating hybrid solar and battery storage systems, and predicting equipment failure. Both fundamental and applied researches are leveraging AI to revolutionize the energy industry to utilize the capabilities of renewable energy.

---

<sup>18</sup> Wilkinson, M. *et al*: The FAIR guiding principles for scientific data management and stewardship. *Scientific Data*, 3, 160018, 2016

<sup>19</sup> HLEG 2018, 2nd High Level Expert Group on the EOSC: Final report and recommendations, 2018.

### 3.2.2 Objective

There are several topics that could be approached by Data Science and Artificial Intelligence methodologies. In a first phase of this tJP, i.e. that associated with its launching, these are the objectives that have been prioritised by the EERA community.

#### Implementing FAIR and open principles

As aforementioned, for supporting the development of a valuable and exploitable data governance infrastructure, it is a must to build capacities based on FAIR and open principles taking into account data security, privacy and sovereignty requirements. In this regard, several tasks are crucial to be developed by the tJP DfE:

- **Task 2.1** Establish a regular forum in EERA across JPs to discuss FAIR and open data standards across JPs
  - It would be of interest to connect with the series of workshops organized by EERAdata on a bi-yearly modus to use synergies
- **Task 2.2** Conduct FAIRification activities and workshops for all JPs in the next 3 years to work towards acceptable and mature standards for FAIR and open energy data, including metadata standards
  - It would be possible to build on the work done in JP Wind through the projects IRPWind and ShareWind.
  - Completion and linking of existing metadata islands to generate an interlinked metadata structure for the energy domain by mid-term. Again, this process is organized back-to-back with ongoing work in the project EERAdata
  - Systematically assess and monitor progress of relevant data bases and repositories used by JP members to identify where the gaps are and how to bridge them. The assessment with regard to FAIR/O criteria could be an outcome of different workshops/hackathons done by the tJP. The process could be supported through using automated assessment tools<sup>20</sup>. Such testing takes about 10-20 min per database.
- **Task 2.3** Building a community for FAIR and open energy data beyond EERA. Through reaching out to other existing initiatives, projects, and networks, as well as to pan-European initiatives, e.g. EOSC, RDA, and OpenAIRE, FAIRsharing, GOFAIR etc. The objective is to build a critical mass for the development and formal approval of FAIR and open (meta-)data standards in the energy domain. Again, synergies with EERAdata should be used.
- **Task 2.4** Bringing together platform services for FAIR and open data. The long-term objective is to establish EERA as the hub for energy researchers and energy data businesses in Europe to find, access, and exchange energy (meta-)data.

*Conceptual models and exchange standards:* FAIR principles; Metadata harvesting; Open access; Linked metadata; Dublin core; Persistent identifiers; Licensing.

*Tools and services:* OAI-PMH; Dublin core.

#### Developing Artificial Intelligence methodologies

---

<sup>20</sup> The license could be obtained for EERA and use for all JPs as well as members of the EERAdata project (details to be agreed, pricing: as that of 2020 for the first year of 1,200 €, following years 450 €. A reference for this kind of tools is available at M.D. Wilkinson *et al.* Evaluating FAIR maturity through a scalable, automated, community-governed framework. *Scientific Data* **6**, 174 (2019).

AI methodologies are becoming more and more useful nowadays. Their capacity for extracting valid information from huge sets of data, providing digital services with an acquired knowledge for forecasting trends, or using images for recognizing different behaviours, characteristics, or definitions are becoming crucial in many sectors.

This fact is endorsed by the creation of several national strategies in AI in most of the European countries, the creation of the European Union High-Level expert Group on AI, or the investment in AI in the framework programmes such as H2020 and HEU.

Within this tJP, the following tasks have been identified.

- **Task 2.5** Linking of FAIR and open data services with AI tools and services. It is usually said that AI is only as smart as its data, so this Task will act as a link between the format and curation process that FAIR and open data services within EERA will design for a seamless connection with the protocols that different AI tools could need and vice versa.
- **Task 2.6** Machine Learning can provide an enormous potential for managing problems related to obtain optimum balance or trade-off between different parameters, for example, offer, demand, and needed storage in energy matters. Besides major areas such as reliable forecasts and smart grids, many other aspects come into play for which great advances are to be expected thanks to machine learning techniques, let's say, prevention of power theft, detection, prediction and prevention of power and hardware failures, or availability of decision-making tools just to mention a few. Some of these problems have been approached in the past with stochastic processes that can still provide valid solution in many cases, included multi-objective functions.
- **Tasks 2.7** Deep Learning has demonstrated its capability for discovering inherent nonlinear features and high-level invariant structures in data, for example, in deterministic and probabilistic forecasting methods which can be lately improved by error post-correction methods and hindcasting techniques. In particular, deep neural networks have become increasingly attractive as an AI approach due to their robustness and flexibility in handling nonlinear complex relationships on large scale data sets.

*Conceptual models:* Stochastic processes (genetic algorithm, simulated annealing, Basin hopping, gradient descent, metropolis Hastings...); machine learning; deep learning.

*Tools and services:* Regression; Classification; Clustering; Dimensionality Reduction; Ensemble Methods; Convolutional Neural Network; Recurrent Neural Network.

### 3.2.3 Identified topics and expected output

Topic	Expected output	by	Expected deliverable
Technical Challenge	Identification of Repositories and data bases of interest for the energy communities	2021	Report on the repositories and data bases (public)
Technical Challenge	Identification of AI tools and services of interest to EERA	2021	Report on the technical requirements to be implemented

Technical Challenge	Identification of metadata standards for the low carbon energy community	2021	Report on the metadata standards
Technical Challenge	Identification of technical methodologies to be implemented for seamlessly connecting repositories to AI tools and services	2022	Report on the technical requirements to be implemented
FAIRifications workshops with all JPs held	# of workshops, # of participants;	Ongoing, end by 02/2023	Report (public) – All deliverables from the EERAdata project and the EERAdata wiki (incl. work added through tJP activities).
FAIR data forum and platform service available	Website, repository etc.; # of parties beyond EERA involved/contacted	2023	Connected to EERAdata deliverables.
Formal approval of FAIR and open energy data standards	# date and vote of decision	2024	Formal minutes.

Table III: Identified topics and expected output for the HPC DS&AI

### 3.2.4 Contacts

<i>Company name</i>	Høgskulen på Vestlandet
<i>Contact person</i>	Pr. Valeria Jana Schwanitz (Data Science) proposes herself as main contact for the Data Science topic
<i>Postal address</i>	Høgskulen på Vestlandet, Postbox 7030, 5020 Bergen, Norway
<i>Country</i>	Norway
<i>E-mail</i>	valerias@hvl.no
<i>Telephone</i>	+47 57 67 61 25

Table IV: Identified contacts for the SD&AI SP

## 3.3 ESI tSP “Technology”

As per the understanding of Energy Systems Integration (ESI) refers an energy system to an integrated group of components used together to produce, convert, transport/distribute, store, consume energy across different sectors (heat, electricity, mobility, etc.). Systems sizes might range from the household scale over regional to the national and even international scale. Variables to design, manage and control energy systems are environmental (e.g. weather and climatic conditions) technical (characteristic and condition of the components), economic (installation, operational costs and revenues), and regulatory (restrictions on installation, subsidies etc.) ones with a strong human dimension (e.g. stakeholder acceptance and behaviour/habits). The JP ESI is therefore of multidisciplinary dimension.

### 3.3.1 Background

Energy systems have evolved over decades from individual energy devices and small sub systems into a complex set of systems, both physical (e.g. electricity grids, gas networks, district heating), institutional (i.e. regulatory and economic) and at all scales (i.e. individual buildings, neighbourhoods, national and international scale). The energy system is indeed so wide that it can be defined as “the whole set of technologies, physical infrastructure, actors (consumers, market parties and network system operators), institutions, policies and practices, located in and associated with a geographical area, which enable energy services to be delivered to consumers”<sup>21</sup>.

These systems are increasingly integrated physically (e.g. combined heat and power and electric vehicles), institutionally (e.g. gas/electricity markets) and across scales (e.g. demand side management in power grids). The interactions are driven by a desire to improve performance, increase efficiency and are enabled by ubiquitous cheap data and control infrastructure and political and economic cohesion (e.g. European Union). The interactions are not limited to purely energy systems but interact with other large-scale infrastructures including, transport and significantly water<sup>22</sup>. Due to these interactions and interdependencies, the energy system is a system whose properties are not fully explained by an understanding of its component parts; its properties only emerge from the interaction of its component parts. These considerations point clearly to the need for appropriate methodologies and tools which are able to capture these interactions.

The main elements necessary to model, simulate, and operate integrated energy systems are the collection of data and information, their processing and use in models and tools which might be physics or data based or a combination of them (grey box model). Furthermore, models and tools need to be coupled and integrated for exchange of data and information as well as for closely interconnected simulation. Real case integration demonstrates the need to allow for an efficient coupling of and information exchange between components covering a wide range of technological generations resulting in additional challenges for optimisation and operation.

JP ESI therefore understands digitalisation as a necessary method/tool to model, simulate and control closely integrated real world energy systems and their interaction with other sectors to reliably and efficiently balance generation, distribution, demand and storage.

It is worth mentioning the all these activities are being carried out as part of the ERA-Net project “Regional Renewable Energy Cells – R2EC”<sup>23</sup>.

### 3.3.2 Objective

The objective of digitalisation in the context of integrated energy systems is the collection, storage and processing of data and information from a wide range of (data-)sources and the coupling of various methods and tools. The aim is to optimize the design and operation of IES towards efficiency, economy and resilience from the perspective of the market operators. From the consumer perspective are objectives the ease-of-use, privacy and environment-friendliness.

#### Collection of relevant data and information for modelling and simulating integrated energy systems

---

<sup>21</sup> Chaudry M. et al., *Building a Resilient UK Energy System*, UKERC; 2009

<sup>22</sup> It is estimated that 13 % of electricity load in the United States is for water related purposes, <http://www.rivernetwork.org/resource-library/carbon-footprint-water> and the energy system is a large user of water e.g. energy production is responsible for 15 % of all water withdrawal <http://www.worldenergyoutlook.org/resources/water-energy-nexus/>

<sup>23</sup> <http://r2ec.eu/>



**Task 3.1:** Identification of minimum required data

Targets: Define minimum amount of data and information required for modelling and forecasting.

This task aims at the definition of the number of sensors to be used and applied (preferably connected to their positioning), as well as to define the ideal sampling rate. This will contribute to reducing costs for installation and operation / service and maintenance. Investment into infrastructure for data handling and storage is also closely connected as well as the related energy consumption (life cycle as well as operation).

Number of sensors and sampling rates largely depend on the energy system, its components, size, and energy vectors included. In addition is the purpose of the project important. Long term scenarios require a different resolution of input data than short term ones or those targeting control. While electrical systems might require a high resolution is a lower one sufficient for thermal systems due to their comparatively high inertia.

Depending on the subject of a project might therefore numerical methods and tools which are to be used vary and are selected to fit to the purpose.

Appropriate formats and protocols for online data (e.g. from smart meters or other high frequency measurements) are a necessary input for modelling, optimisation and control at all levels of aggregation.

**Task 3.2:** Integration of non-sensor-based data and information

Targets: Integration of information which is not based on sensors and might impact recorded data and therefore the interpretation of the data.

This information might result from services and maintenance (e.g. exchange of sensors, services that impact the performance of components ...) and / or upgrade of components within the energy system. Information on potential changes in generation or demand profiles which for example might result from changes in the availability of raw material in processes (e.g. fish industry) etc. contribute to the reliability of operation or forecast and therefore the reliability of the energy system. Possibilities for demand control are information which is not necessarily available digital but again might impact integrated energy systems. Privacy and security of data and information are closely connected topics.

*Conceptual models:* connection to sensor data, collection and integration of this data

*Numerical models:* To be developed

Hybrid and data driven tools and methods for modelling and forecasting

**Task 3.3:** Most energy systems are exposed to variations of different time scales, ranging from seconds to seasons.

Targets: Developing and providing the necessary know-how and technologies for aggregation, forecasting, control and optimization on all relevant temporal and spatial scales.

Most data driven tools require a representative coverage of operating conditions for training/learning. Therefore, it is in many cases beneficial to operate with hybrid (or grey box) models which combine physical models with data driven ones. In this context will aggregation play a central role, and the appropriate choice of models and methods for forecasting, control and optimisation vary across different aggregation levels. The goal is to have a unified set of approaches which ensures that the various components of the energy system (across different scales, locations and energy vectors) fit in to a common overall framework for forecasting and control.

*Conceptual models:*

- Develop the necessary customisations of and improvements to meteorological (MET) model as required by the IES. This will often require special parameterisations of the physical models.
- Develop methodologies for forecasting in an ESI context with a focus on both probabilistic and multivariate aspects.
- Develop principles and methods for aggregation, and provide key inputs to the forecasting, control and optimization. The aggregation techniques and principles will be tailored to each level of the hierarchical Energy system.
- Develop and formulate controllers which can be used across a number of technology areas, and this common formulation will permit multivariate control based on multivariate forecasting.
- Develop methods and tools for in particular non-convex optimization problems which are often seen in relation to ESI. Methods for decision support, the relationship between optimisation problems and real time control problems in a hierarchical setting will be considered.

*Numerical models:* to be developed.

### Modelling and tool integration

The aim of this task is to develop new methodologies, technologies and solutions that ensure an efficient interaction between the various actors and components of the system, with a holistic approach that takes into account the potential synergies between the various energy networks (electricity, gas, oil, heat and mobility). It shall improve the understanding of modelling of the interactions between energy sectors at different temporal and geographical scales.

This leads to:

- Establish fundamental approaches for modelling of integrated energy systems and assess the value of flexibility through the interaction between different energy sectors, infrastructures, and emerging technologies;
- Provide insights on the role of system optimisation to help the transition towards a low-carbon system, by identifying the potential synergies and trade-offs between the evolution of the various components of the system, i.e. its energy carriers (fuel pathways at all scales), technologies (at each step of the value chain), institutions (e.g. the various electricity markets, the gas market);
- Enhance the understanding of resilience when considering the whole energy system (including links with water and weather), and propose modelling approaches to quantify and enhance future energy systems' resilience;
- Develop approaches to modelling of local and regional/country level Energy systems as well as their interactions and dependences

*Conceptual models:* Modelling of large systems, design of algorithms for trade-offs evaluations and analysis.

*Numerical models:* to be developed.

### New paradigm related to SP1 and SP2

The SP Technology (ESI) makes use of HPC capabilities for:

- HPC capabilities will be used where appropriate. Its use might depend on the sizes of the systems and models and tools used. This will be also related to required level of detail in simulations and modelling.

Also, the SP Technology (ESI) makes use of Data Science & AI capabilities for:

- Collection of operational data and information as being relevant for control and optimisation tasks of integrated energy systems.

### 3.3.3 Identified topics and expected output

Topic	Expected output	by	Expected deliverables
Definition of the minimum amount of data and information required for modelling and forecasting	Reduction of costs for installation and operation / service and maintenance.	2021	State of the art. Perspective / feature paper published by several partners.
Integration of non-sensor-based data and information	Improvement in the reliability of operation or forecast and the reliability of the energy system	2022	State of the art. Perspective paper published by several partners. Material property library for IA based computing tools.
Aggregation, forecasting, control, and optimization on of relevant data under temporal and spatial scales	Model local and regional/country level energy systems as well as their interactions and dependences	2023	Perspective paper published by several partners. Material property library for IA based computing tools

Table V: Identified topics and expected output for the ESI tSP

### 3.3.4 Contacts

<i>Company name</i>	VTT Technical Research Centre of Finland Ltd (VTT)
<i>Contact person</i>	Pr. Juha Kiviluoma (Modelling)
<i>Postal address</i>	Vuorimiehentie 3, Otaniemi, Espoo
<i>Country</i>	Finland
<i>E-mail</i>	juha.kiviluoma@vtt.fi
<i>Telephone</i>	+358 20 722 111

<i>Company name</i>	Danmarks Tekniske Universitet (DTU)
<i>Contact person</i>	Pr. Henrik Madsen (Forecasting)
<i>Postal address</i>	Anker Engelunds Vej 1 - Building 101A - 2800 Kgs. Lyngby
<i>Country</i>	Denmark
<i>E-mail</i>	hmad.dtu@gmail.com
<i>Telephone</i>	+45 45 25 25 25

<i>Company name</i>	NORCER Research
<i>Contact person</i>	Pr. Peter Breuhaus (Technology)
<i>Postal address</i>	Nygårdsgaten 112 - NO-5838 Bergen
<i>Country</i>	Norway

<i>E-mail</i>	pebr@norceresearch.no
<i>Telephone</i>	+ 47 56 10 70 00

Table VI: Identified contacts for the ESI tSP

### 3.4 AMPEA tSP “Multiscale modelling of materials, processes and devices”

The goal of this SP is to coordinate a concerted effort to identify current challenges and forthcoming trends in multiscale modelling and simulation. This effort is critically important in advancing materials, processes and devices for energy applications, while ensuring sustainable production route and fostering circular economy: firstly, innovative energy materials are often complex structures or “high technology” products (multi-functional), which cannot be described by basic models; secondly, the formation and application of such structures are very much dependent on conditions of processing and utilisation; and thirdly, the integration of such materials in devices is intricate and thus requires careful design and optimisation. All of these issues encompass multiscale spatial and temporal dimensions of tens of magnitudes, where cross-disciplinary work is a necessity.

Furthermore, during the recent years with the rapid evolution of computing resources and the related advances in programming a new paradigm related to artificial intelligence, machine learning and cloud computing arises. This new way to think informatics is about to revolutionize our methods in designing, modelling and describing material properties and should contribute to shorten the timing of new materials discovery.

#### 3.4.1 Background

In order to develop and deploy efficient materials and processes in energy applications, an integrative approach that combines theory, models, simulations, fabrication and characterization should be considered. Among these research areas, “modelling and simulations” are a powerful toolbox, which can open the way to innovative design of new materials and new production routes for energy applications. However, conventional tools and models developed to address to date are often confined within small-scale domains and inadequate to materials that involve nanostructures, microstructures, composite and alloy phases. Similarly, they are not suitable to investigate intensified processes that combine heat and mass flow transfers, electronic and chemical transports, mechanical loads, transient operations, etc. For such complex but real-time applications, multiscale modelling could bring critical insight in materials and processes limitations, and thereby, open routes for optimization. Hence, dedicated numerical simulations need to be established to address these specific requirements. Besides, in what concerns new materials and processes for energy a cross-disciplinary approach is essential. As discussed in the following, models and tools developed to predict transport properties of innovative materials are interdisciplinary and more and more used for research and engineering purposes.

In this framework, several actions have been achieved in AMPEA and examples of integrated computational material engineering such as the development of the VTT Propertune TM environment will be discussed hereafter. Besides, a common reflection with the European Center of Excellence dedicated to the computation in the field of Energy (EoCoE) has started to identify common interest that might foster interaction between two different communities, i.e. the physic and computational ones.

The main goal of Multiscale modelling SP is to provide tools that can support research and developments in the identified application sub-programmes (Artificial photosynthesis, Advanced materials for heat exploitation and energy conversion, Materials for extreme operating conditions) as well as for the other emerging fields or other EERA Joint Programmes where materials and processes challenges are important. Therefore, simulation tools devoted

to the specific length scales of interest, which can address several physical phenomena, are necessary. Between material atomistic properties and its integration in a process or a device several problems must be investigated:

- Identify what are the relevant models to be applied from the atomic scale that characterize the material to the system scale related to its integration in an energy production device.
- Relate models and numerical simulation tools; find the most efficient solving techniques and quantify their reliability and their accuracy, for example by defining and using benchmark test cases to address models and tools exactitude. Use of small-scale prototypes to compare simulations and experiments.
- Discover and investigate through data mining and machine learning new materials for energy applications, especially taking into consideration raw material abundance, toxicity, availability, etc.
- Considering a bottom-up modelling approach, identify the key properties that rule the functionality of the whole device and find the most appropriate techniques to minimize the impacts of the involved parameters in the numerical solution of a given problem, e.g. using effective medium theory, or model reduction techniques.
- Propose efficient techniques to achieve the coupling between different physics such as heat and mass transport, chemical and biological or mechanics and electric interactions, etc.
- Consider the crosscutting issues between this sub-programme and the other joint programmes dealing with energy applications (e.g. Fuel Cells and Hydrogen, Energy storage, Photovoltaic, etc.).

Calculations, which were done on personal computers a decade ago, are now routinely done on super-calculators, PC clusters or in the frame of grid and even cloud computing. This allows achieving calculations involving complex models and boundary conditions but also very thin meshes and small-time steps. Among the recent progress done in this field, very fast phenomena occurring at atomic scale can now be addressed or complex interactions at macroscale in realistic engineering devices and processes. **Thus, one purpose of this work-programme is to make a detailed survey of the existing tools that can be applied to the Joint Programme objectives and to anticipate the arising of new the ones, like the one related to artificial intelligence, at once.**

In the frame of material modelling a broad range of numerical tools presently exist. From the atomic scale to the microscopic one, an incomplete list could be; ab-initio techniques, Molecular Dynamics, Monte Carlo models, discrete element methods. These simulation tools have in common to make few (or no) assumptions and are frequently identified as reference techniques. However, their implementation is often delicate and strongly dependent of the considered problem. These techniques belong to the family of “discrete methods” and get their name from the small scales for which they apply.

Oppositely, when system size becomes larger or when several physical coupling should be considered - as an example the processes taking place at electrochemical interfaces, or for reactive phenomena - these methods are no longer applicable with the current numerical resource and other techniques must be used. The latter ones belong to “continuum methods” and the material is considered as an equivalent media with homogeneous and averaged properties. These methods are commonly used for engineering purposes; the widely known are the finite volume methods, the finite elements, the meshless methods, etc. They are very often employed for computational fluid dynamics, heat transfer, solid mechanics etc. However, a comprehensive outlook of models and simulation tools shall also include the mesoscopic scales, at the intersection between discrete and continuous behaviour. They explain the transition of fundamental transport properties of materials when characteristic size of the system becomes of the same order as the associated mean free path of energy carriers;

e.g. phonons in nanostructures, electron transport, ions in membranes and fuel cells, complex fluids, etc. For such applications, models and simulation tools are not well established and are frequently a compromise of discrete and continuous approaches. Usually here in-house codes are developed based on e.g. MATLAB and / or SIMULINK.

The following European projects / grants are focusing on topic such as: the investigation of electrochemical interfaces by multiscale modelling, nuclear safety through multi-physic modelling of reactor systems, modelling of geomaterials:

- “Multiscale Modeling and Design of Pholo-Electrochemical Interfaces (MuMo4PEC)”, MERA.NET project grant number: 4089<sup>24</sup>
- “Computational materials sciences for efficient water splitting with nanocrystals from abundant elements”, COST action no. 18234<sup>25</sup>
- “ESFR-SMART (European Sodium Fast Reactor Safety Measures Assessment and Research Tools)”, Euratom Research and Training Programme, grant number: 754401<sup>26</sup>
- “GeoRes - Geomaterials: from Waste to Resource”, MSCA-RISE project, grant number: 778120<sup>27</sup>

### 3.4.2 Objective

On this basis, important challenges of this sub-programme will be:

- Propose a global and versatile methodology to address and bridge atomistic and microscale features (transport properties calculation and tailoring, nanostructuration effect, interfaces, volume/surface effect, microkinetics, etc.) for innovative materials intended for energy applications;
- Identify clearly the new ways to achieve large-scale calculations (including data mining) through Exascale High Performance Computing, machine learning and artificial intelligence.
- Define properly mesoscales related to the applications of interest and identify the key parameters which allow the coupling between discrete and continuous modelling;
- Work on integrated multiphysic modelling and simulation to address engineering problems related to devices and processes in connection with energy issues.

This can be considered as a possible updated roadmap to succeed in efficient modelling and simulation of materials, processes and devices. In the following, these four main challenges (WPs) are listed. Grand challenges are in the core of some AMPEA actions and lead to specific events such as workshop and dedicated Joint Program Steering Committee (JPSC).

#### Small scales models and tools – materials

Small scale modelling is fundamental to study and predict physical properties of materials. For the lowest scales, electrons which are responsible for the chemical bonds between atoms, govern these materials properties. Thus, the determination of the electronic structure of the considered materials and an intelligent transfer of its characteristics to higher-order scales using multidisciplinary schemes is a crucial issue. The latter one can be obtained with quantum mechanics using the first-principles, or ab-initio methods. These models often lie on the Density Functional Theory (DFT) which provides with very few assumptions the electronic

---

<sup>24</sup> <https://www.differ.nl/network/mera-net>

<sup>25</sup> <https://comp-h2o-split.eu/>

<sup>26</sup> <http://esfr-smart.eu/>

<sup>27</sup> <http://emps.exeter.ac.uk/engineering/research/computational-geomechanics/geores/>

properties of a material. Using these data one can recover various properties such as: dispersion properties, band gap in semiconductors, optical absorption spectra, thermal expansion properties, Young's modulus, electrochemical overpotential, H adsorption energy, etc. However, ab-initio techniques remain quite difficult to implement, are limited to atomic structures which are not too large (roughly hundreds of atoms), and usually rely on the solid-gas interface, while several energy applications consist of a solid-liquid interface. Ab-initio techniques are useful to provide reliable inputs to models and simulation tools operating at "larger" small scales, such as molecular dynamics, Monte-Carlo, or continuum methods.

For nanostructures such as nanowires, nanofilms, quantum dots, superlattices, etc. other modelling tools like molecular dynamic are well suited and allows the determination of thermal and mechanic properties. This technique lies on the monitoring of the displacement of an ensemble of atoms due to interacting forces. The latter ones usually derive from (conservative) "potentials that can be obtained either by ab-initio calculations or through empirical considerations. Different kind of molecular dynamic methods exists according to the targeted application.

*Conceptual models:* Quantum mechanics using the first-principles; ab-initio methods; molecular dynamics; Monte-Carlo; Density Functional Theory (DFT)

*Numerical models:* LAMMPS<sup>28</sup>, VASP<sup>29</sup>, Phonopy<sup>30</sup>.

#### Mesoscales and large scales models and tools – devices and processes

When the characteristic size of studied material becomes large regarding to the atomic or molecular scales, small scale modelling previously discussed is no longer possible. The first reason is that computing requirement is not today available. Moreover, for mesoscales and large scales, materials are usually not perfect and there exist structures such as defects, cracks, grain boundary, etc. According to the parameters of interests, modelling and simulation can be carried out at mesoscales, considering local effects, or at large scales assuming homogeneous properties. In the frame of material design for energy application, techniques such as Monte-Carlo solution of transport equations can be very efficient for mesoscales, whereas numerical tools like finite volume methods, finite elements, etc. are often used to solve coupled transport equations at large scales.

For mesoscale modelling it is often complex to find the "good" physics and its limits. In such a case, simulation parameters often lie on the small-scale modelling results which provide the laws and/or the material constitutive relation that shall be considered. On the other hand, in the case of large-scale simulations there is a plethora of numerical tools that can be used to study solids and fluids energy materials. Integrated tools like Comsol Multiphysics (finite elements) or ANSYS Fluent (finite volumes) can even address complex engineering problems where dedicated parameters and behaviour law appraised by small and mesoscale models can be possibly implemented. Besides, in some cases, these tools can also address chemical or species transport occurring in devices or processes. Whatever will be the chosen tools, there is often large user community involved in the development of the applied physics' software. Furthermore, what is important for all mesoscale and large-scale models is the interface and bridge to experimental data. Modelling the same data that can be measured in experiments allows for better analysis of experimental data, predicting experimental data and by this being more cost effective, as well as screening of materials properties regarding highest performance.

---

<sup>28</sup> <https://lammps.sandia.gov/>

<sup>29</sup> The Vienna Ab initio Simulation Package (<https://www.vasp.at/>)

<sup>30</sup> <https://phonopy.github.io/phonopy/>

An example of this type of multiscale achievement including modelling stages ranging from the microstructure description to the design of product and their in-operando use can be found in the VTT Propertune tools dedicated to encompass the concept of “factory of the future”. This computing environment developed by colleagues of VTT, involved in AMPEA, is an advanced computational modelling-based material design environment. Another example is the modelling of an electrochemical interface, such as the oxygen evolution reaction in water splitting (example: MERANET project “MuMo4PEC”). Here, the same electrochemical data as measured in experiments is simulated in a continuum model representing the electrochemical interface and having atomistic simulations as input. For such modelling, commercial software does not exist and in-house codes need to be developed.

*Conceptual models:* Monte-Carlo solution of transport equations; Finite volume method; Finite element method

*Numerical models:* Comsol Multiphysics (finite elements); ANSYS Fluent (finite volumes); Propertune tool; in-house made modelling codes based on e.g. MATLAB / SIMULINK / FORTRAN.

### Integration, model order reduction and applied tools

Efforts for integration of different simulation platforms will be carefully considered both in terms of prediction accuracy and capability. In several practical cases, indirect coupling or interfacing is sufficient, at least as a first attempt, to achieve data and information passing across different simulation platforms. In others, direct integration may be more valuable, but will require much more dedicated resources and advances in methodologies and simulation schemes.

In what concerns model order reduction (MOR), such an approach becomes unavoidable when models and simulations point to describe the dynamical behaviour of a complex system. In this case, even if the small and large scales physics are well understood, the number of involved parameters is simply too large to be handled by the current computational devices. For this problematic, MOR is a way to preserve the accuracy of calculations and to decrease the computational time. For such an approach two major issues must be considered: firstly, reduced models must be stable to ensure numerical simulation convergence and secondly the quantification of the error generated by the model reduction needs to be evaluate. Yet, this technique can be applied to numerical prediction in a broad range of application including: fluid dynamics, material deformation, structure vibrations, etc. It could be also used for active control or optimization in process monitoring.

*Conceptual models:* Model order reduction (MOR)

*Numerical models:* Matlab<sup>31</sup>, PyMOR<sup>32</sup>, ANSYS-ROM<sup>33</sup>

### New paradigm related to SP1 and SP2

During recent workshops hold in 2017 and 2018, and more specifically after fruitful exchanges with EoCoE representatives, several issues about new computation paradigm were raised. In the following, a non-exhaustive list of the latter is given representing in this way strong synergies with this tJP DfE’s SP1 and SP2. They are not ordered in terms of importance but shall retain attention as they could drastically change our way of designing and modelling materials for energy.

---

<sup>31</sup> <https://www.mathworks.com/>

<sup>32</sup> <https://pymor.org/>

<sup>33</sup> <https://www.ansys.com>



- Material simulation is now often based on small-scale approaches, i.e. considering atoms and electron interactions (as discussed in WP1). These so-called DFT, Quantum Monte Carlo, Molecular Dynamics, etc. are very promising and give a very accurate understanding of phenomena that underlie material properties (e.g. organization of ionic liquid in pores, amorphization of thin layers on solar cells, impact of defects and substitutions in the elaboration of new catalysts, etc.). Yet, all these methods need important (considerable) computing resources that are not always available or remain expensive. Even if those methods are mostly mature, there is still work to do to increase their accurateness and to catch physical phenomena on larger systems: exascale supercomputers could significantly play a role.
- Databases and material screening. To create breakthroughs in new material discovery with the availability of HPC computing platform, numerical screening of existing material databases is very promising and is a pillar of “Mission Innovation [11]” MI-C6, through “Inverse Design”. In this approach well-chosen descriptors can help identifying the relevant material with the expected properties. Here the following is needed:
  - Standardization for information classification and data structure is needed in databases for materials science.
  - The access to databases to the existing modelling tools should be improved and supported.
  - Classification of descriptors in database analysis needs to be improved and new descriptors are needed to optimize material search
- Machine learning and artificial intelligence (AI). If AI can appear as a complicated tool to manage for new materials exploration, especially in a whole integrated process (simulation, elaboration, characterization & feedback) suggested by MI-C6, machine learning is a key tool to accelerate computational design of materials on an integrated platform:
  - The energy material sector could largely benefit by such approaches. Indeed it could be interesting to develop materials knowledge repository for energy materials and devices (enough feedback, data to develop appropriate algorithms).
  - Issue of trial/error approach. In order to succeed in the development of a machine learning process, not only experimental/numerical techniques are needed. Errors and misleading attempts are also useful to develop a critical reasoning. New knowledge must be fed back to the scientific community and stakeholders by reporting problems, coding new types of analyses and applications, and proposing new but reliable materials for computation.
- Exascale. Exascale is at the core of several projects and Centres of Competences within Europe. Presently, the technology seems not to have reached enough maturity to induce a new way of designing materials, nevertheless it is undisputable that in few years, it will be available. For example, exascale computing has just proven its efficiency in the frame of climate analytics; giving an undisputable proof of the interest of this new computing architecture. Questions are now about:
  - Material design for energy is a vast area: accurate analysis is needed in order to optimize investments to be ready for the new technology. Similarly, a discussion needs to be opened in order to classify in which material science domains this technology leads to real breakthroughs. Clear objectives are to be defined to succeed in this evolution.
  - Not many numerical codes are ready to be ported on the new exascale architectures. A clear assessment is needed.

- Not many scientists in materials science for energy are ready to exploit the new possibilities offered by exascale technologies. Scientific collaborations with HPC experts and communities, like EoCoE, should be largely supported.

### 3.4.3 Identified topics and expected output

Topic	Expected output	by	Expected deliverables
Multiscale modelling of electrochemical interfaces	<ul style="list-style-type: none"> <li>• Granting of a large European proposal on this topic</li> <li>• International conference or symposium organized on multiscale modelling of electrochemical interfaces</li> </ul>	2023	Perspective / feature paper published by several partners. Special Issue in an international peer-reviewed journal on multiscale modelling of electrochemical interfaces
Machine learning based new material properties identification	Funding a large European proposal on this topic with commitment of HPC European and National computing resources	2023	State of the art and Perspective paper published by several partners. Material property library for IA based computing tools.

Table VII: Identified topics and expected output for the AMPEA tSP

### 3.4.4 Contacts

<i>Company name</i>	Lorraine University (UL)
<i>Contact person</i>	Pr. David Lacroix
<i>Postal address</i>	2, Av de la forêt de Haye, 54505, Vandoeuvre
<i>Country</i>	France
<i>E-mail</i>	david.lacroix@univ-lorraine.fr
<i>Telephone</i>	+33 (0)3 72 74 42 22

<i>Company name</i>	DIFFER
<i>Contact person</i>	Dr. Anja Bieberle-Hütter
<i>Postal address</i>	De Zaale 20, 5612 AJ Eindhoven
<i>Country</i>	The Netherlands
<i>E-mail</i>	a.bieberle@diffier.nl
<i>Telephone</i>	+31 40 3334 801

Table VIII: Identified contacts for the AMPEA tSP

## 3.5 Hydropower tSP “Digitalization”

The scope of Hydropower SP6 “Digitalization” is to find solutions and answers related to digitalization of business processes in hydropower. The SP may cover the whole value chain including planning, building and renewal, maintenance and asset management, production planning, marked analysis and environmental monitoring. Digitalization provides new opportunities in many sectors, and hydropower is no exception. The overall aim is to reduce costs and increase the income for the entire lifespan of hydropower assets. This is done by optimizing business operation with improved business processes and models. Digitalization goes beyond automatization, digitization (converting analogue to digital data) and using digital tools. Thus, digitalization will change the way how a utility runs the business.

The SET-Plan key actions most relevant for this SP are:

- Reduce the cost of key renewable technologies
  - Coordinated scheduling of maintenance and operation will save costs on the long term.
  - Avoid scrapping of useful equipment by predictive maintenance.
  - Balance increased income and increased wear and maintenance cost from new operating patterns.
- Develop higher performance renewable technologies integrated in the energy system
  - Increase the share of system services from small-scale hydropower.
  - Installation of small pumped storage as an enabler for the integration of more renewable energy into the distribution grid level of the energy system.
- Increase the resilience and security of the energy system
  - Increased awareness of the condition of the hydropower plants in the energy system.
  - Facilitate the integration of small-scale hydropower (web-of-cells).
  - Virtual power plants supporting ancillary services.
  - Additional flexibility from hybrid power stations with hydropower and batteries.

### 3.5.1 Background

As digitalization in the hydropower sector is still very young, the experience and knowledge are limited. Operators are now actively developing strategies to digitalize their business. Digitalization builds a cross-sectional function between traditional areas such as turbine engineering, and new areas such as data handling and visualization. From this perspective, one of the biggest challenges is how to integrate the expertise of professionals from different disciplines. The focus in SP6 will be on testing of existing methodologies and concepts and methodologies and applying them to relevant hydropower applications rather than on development of new basic/fundamental IT and data analysis methodologies and technologies. Thus, identification of good use cases and conduction of pilot and concept studies both in the lab and the field are of major interest for this SP. The aim is to bring together the domain knowledge of hydropower with the domain knowledge of IT and data science. By connecting cross-domain competence with real-world use cases, the SP can identify the need for research in both domains and act as a catalyst for development and application of new methodology and technologies.

Some examples of ongoing projects in which these methodologies are being developed are the Hydropower Plant Simulator<sup>34</sup> (a tool to determine the influences of the free energy market to the refurbishment decisions of a Hydropower Plant) or REVEX<sup>35</sup> (an online tool to determine the optimal refurbishment time for a Hydropower Plant).

#### Predictive Maintenance

One important topic to be addressed is the relation between operation, loads, degradation and lifetime. Operational changes, such as more frequent load changes and faster power regulation, increase the loads on the components and thus may increase degradation and reduce lifetime. Digitalization will help to get better knowledge about these relations, for example, through better access to relevant data, more and smarter sensors, and better methods for data interpretation. Identifying typical fault patterns in both, old and new sensor data with different quality is a big challenge. Accordingly, taking advantage of the new

---

<sup>34</sup> <https://www.hydropps.org/#>

<sup>35</sup> <https://www.inso.tuwien.ac.at/>

technology such as calculated sensorics with edge computing, can increase the efficiency of the data exploration process.

To realize the potential for value creation from digitalization, the hydropower producers must build processes that can utilize information from parallel business areas. An example is maintenance of power plants, where we can expect that digitalization will change traditional maintenance processes from regular manual inspections, to monitoring and surveillance of components resulting in a shift from time-based and scheduled maintenance to condition-based and predictive maintenance. By integrating this optimized maintenance with optimization for production planning there is an even larger potential for value creation.

### Flexibility

In today's market, the flexible power offered by hydropower is restricted by conservative limitations set to the operating range of the generating units. This is in place to safeguard long service life of these units. By allowing more versatile exploitation of the generating units, more flexible power can be offered. The versatility comes at a cost that needs to be known if this strategy is to be employed. A key question here is if digital twins of generator units can lead to a breakthrough in calculations of the reduced remaining life of new operating patterns?

One of the goals of the Energy Union is free flow of energy without technical or regulatory barriers between countries. At the same time, hydropower has the potential to become an enabler for integration volatile renewable resources into the power system on a local level. Will new digital market platforms open up for more flexibility from hydropower on both local level and across countries? Which new business models will develop on such platforms?

### Security

Industrial IT systems have witnessed an increasing number of cyber-attacks in the past two decades. The technical reasons for this are twofold: First, there is a trend in industrial control systems (ICS) to replace proprietary protocols, operating systems and hardware by standardized and off-the-shelf products. As a consequence, many vulnerabilities of general-purpose ICT systems now also appear in ICS. Second, more and more ICS are connected to the company network or even the Internet in order to simplify their management (e.g. by providing remote access to engineers) or to allow business departments to access production data and influence production in real time. Not surprisingly, there are also attacks against critical infrastructures, such as electricity generation and distribution systems. In fact, they are of special interest for attackers because a successful attack can cause widespread disruptions. For example, the cyber-attack against the Ukraine power grid in 2015 left about 230,000 people without electricity for up to 6 hours.

Concerns over cyber-attacks against hydropower plants have increased in recent years. IT systems in hydropower plants are less regulated than, for example, their counterparts in nuclear power plants. An intruder could do significant damage by manipulating the plant's dam gates. There has been a study of a hypothetical scenario where an attacker opens all gates of a hydroelectric dam and causes rapid and massive flooding downriver as well as damage to the turbines and power station.

It can be expected that many best practices in industrial IT system security can be also applied to hydropower. Those practices include the separation of industrial control systems from other networks and the usage of data diodes where connections between networks cannot be avoided. They also include the application of the principle of defence in depth, for example by deploying multiple intrusion detection and prevention systems that operate on different levels (network level, application level). However, hydropower also has unique properties that could lead to new types of attacks and that must be addressed by researcher.

For example, if several plants are located at the same river, an attack against a plant could trigger a chain reaction on plants downriver.

### Digital transformation

Digitalization shows also opportunities in field of social aspects. Digital workforce management and especially Know-How management in terms of maintenance and operation are a crucial topic today. Knowledge based databases and virtual realities could act as a pathfinder in this direction. In collaboration with SP5, research could contribute with research on topics such as organizational culture, institutional learning, and industry acceptance. To realize the potential for value creation from digitalisation, industry must have willingness to accept and trust new technology such as machine learning and big data analysis tools, which may replace former manual processes. Is it equally interesting investigating how to limit the complexity level for users, while the complexity inside the expert tools is growing?

### **3.5.2 Objective**

Digitalization in hydropower is not an established and traditional research topic. The topic merges two quite different fields. Thus, the research priorities and topics to be addressed must be identified in the first stage of the SP. The priorities and topics depend also on the SP members' interests and competences. Since the hydropower business is in the beginning of the digital transformation, establishing an overview of national initiatives and status for different SP partners within the field of digitalization is a relevant initial activity.

The identified SP's objectives are:

- To identify and describe the state of the art within the fields of this SP.
- To identify relevant use cases for digitalization in hydropower.
- To provide an overview of national and international research initiatives within digitalization in hydropower.
- To contribute to better understanding of the relations between operation, loads, degradation and lifetime.
- To identify future challenges, such as, security with more data-based decision making.
- Act as a hub for digitalization initiatives and projects between scientists and industry.

These objectives are structured in specific research priorities/topics identified by this SP described below.

#### Machine-level technological aspects

- Installation and management of monitoring systems.
- Quality assurance and harmonization of data.
- Digital twin of turbine and generator.
- Anomaly detection for critical equipment.

*Conceptual models:* Monitoring capabilities, data management and reusability, digital twins, control systems, field measurements and instruments.

*Numerical models:* SCADA Systems; data standards defined in SP2.

#### System-level technological aspects

- Virtual power plants supporting ancillary services.
- Security and prevention of cyber-attacks.

- Benchmarking of methods for big data.
- Interface towards other digitalization initiatives.

*Conceptual models:* Virtualization, Cybersecurity, big data, interfaces and gateways

*Numerical models:* To be defined in the coming future.

#### Economic aspects

- Cost-effective operation and maintenance.
- New business models from digital platforms.

*Conceptual models:* Cost-effective methodologies, business models, predictive maintenance.

*Numerical models:* To be defined in the coming future.

#### Environmental aspects

- Improving inflow models from new available data.
- Digital twin of river from scanning of riverbeds.
- Model verification based on satellite monitoring of flow.
- Image processing for identifying fish behaviour and effect of fish ladders.

*Conceptual models:* Data analysis, digital twins, deep learning, image processing.

*Numerical models:* To be defined in the coming future.

#### Social aspects

- Acceptance of existing and new technology.
- Mitigation of increased complexity from cross-discipline collaboration.
- Know-How Management in terms of maintenance and operation.

*Conceptual models:* Data analysis.

*Numerical models:* To be defined in the coming future.

#### New paradigm related to SP1 and SP2

There are many common interests and synergies between hydropower, other types of power production, and other industries and sectors. Thus, exchange of experience and knowledge with other sectors, as well as collaboration with other sectors, is of major interest for the work in this SP. The most relevant already established EERA JPs for collaboration and exchange of experience are:

- JP Energy Storage: The results of this SP could serve as input for an optimization on a system level. Other SP's are interesting on a technological level to combine them with hydropower and optimize the "hybrid approach".
- JP Wind Energy, SP 3 Wind conditions and climatic effects; SP 5 System integration; SP 8 Planning and deployment, social, environmental and economic issues: Environmental aspects, economic issues and system integration of the wind sources are definitely a connection point to this SP.
- JP Photovoltaic Solar Energy, SP 5 PV systems: PV Systems play a vital role in the electrical grid and are therefore a good connecting point for a system approach.
- JP Geothermal. SP 6 Operation of Geothermal Systems; SP 8 Computing and Data Management: Operation, Computing and Data Management are key roles in terms of digitalization. In a future world, where more and more utilities are connected, these SP's are prioritized for collaboration.

- JP Smart Cities: Distributing energy in cities will need digitalization and hydropower could act as energy supplier. Therefore, any experience exchange will lead to a better understanding of needs and requirements.
- JP Smart Grids: Flexible distribution of energy and electricity in Smart Grids plays a vital role in the future. JP Hydropower, SP 6 could collaborate very closely in terms of a system approach.
- JP Energy Systems: Hydropower plays a role in electricity production and is therefore part of the energy system mix. The best way to cooperate is on a system level with digitalization as the linkage.

In addition to that, there are connections to the HPC and Data Science & AI SPs being part of tJP DfE. Thus, this SP makes use of HPC capabilities for performing the High Performance Data Analytics previously mentioned, i.e. HPC is used as a service for carrying them out

Thus, it makes use of Data Science & AI capabilities for the anomaly detection or outlier detection in hydropower plants. This is an application of data science and it requires use of AI algorithms. Both in system and machine level, dataset collected from critical equipment or subsystems is used for identifying any outlying or unusual operating points.

### 3.5.3 Identified topics and expected output

Topic	Expected output	by	Expected deliverables
Hydropower use cases	Report on relevant use cases for digitalization in hydropower.	2021	Public report published by the SP community
Hydropower initiatives	Report on national and international research initiatives within digitalization in hydropower.	2021	Public report published by the SP community
Refurbishment	To make available a tool to determine the optimal refurbishment time for a Hydropower Plant	2023	Fully operational online tool.

Table IX: Identified topics and expected output for the Hydro tSP

### 3.5.4 Contacts

<i>Company name</i>	TU Wien
<i>Contact person</i>	Dr. Eduard Doujak
<i>Postal address</i>	Getreidemarkt 9/302 , A-1060 Vienna
<i>Country</i>	Austria
<i>E-mail</i>	eduard.doujak@tuwien.ac.at
<i>Telephone</i>	+ 43-1-58801-302404

Table X: Identified contacts for the Hydro tSP

## 3.6 Nuclear Materials tSP “Physical modelling, materials health monitoring and non-destructive microstructure examination for nuclear materials”

The performance of nuclear materials used in structural components is essential for the development of sustainable nuclear energy. Materials in fast reactors that are part of the upcoming nuclear technologies will be exposed to higher temperatures and higher irradiation

levels than today's light-water reactors. Fast reactors also use non-aqueous coolants, for which the full compatibility of materials still needs to be demonstrated.

In setting the design lifetime, assumptions have to be made with regard to actual material composition, microstructure state, mechanical properties, defect location, defect density, defect size, operational factors such as number and magnitude of temperature and/or pressure cycles as well as neutron flux (fluence rate and dose rate) and the degradation of the mechanical properties during service. The evaluation of these parameters by in-situ inspections would allow the estimation of the operational lifetime of nuclear power plants (NPPs). Hence, in-service inspection for existing NPPs is a powerful tool for supporting safe and reliable operation, i.e. better knowledge of degradation mechanisms and reliable online monitoring enabling one to follow precisely the actual state of the materials in operation are important.

Physical modelling and advanced microstructure examination on the one hand and in-service inspection for nuclear power plants on the other hand are powerful tools to support safe and reliable operation. These topics are closely linked to the topics of the digitalization JP: HPC, big data, Artificial Intelligence.

These SPs address several types of nuclear materials: structural materials (metallic or ceramic), nuclear fuels.

### 3.6.1 Background

This SP aims at providing knowledge, data and tools needed to interpret correctly and extrapolate to real conditions the experimental results devoted to the qualification of materials subjected to reactor-like conditions, as well as to assist in the elaboration of fabrication routes for innovative materials. The focus is on the understanding of the physical mechanisms that determine the response of the material under given conditions owing to the development of physics-based models and the deployment of modelling-oriented experiments. Physical phenomena related to the synergistic effect of irradiation, temperature and environment cannot be supposed to be linear. Incubation times or doses and thermally activated processes may determine the appearance of totally unexpected materials responses above a certain dose or temperature or when subjected to a combination of stresses of different type. Thus, a physics-based prediction of the behaviour of materials in the envisaged in-service conditions must be based on some degree of fundamental understanding of the basic mechanisms acting from the atomic to the macroscopic level and determining their response to the applied environmental, thermal and mechanical loads, while being exposed to neutron irradiation. The build-up of this knowledge is crucial for the safe operation and design of all future nuclear installations.

In addition, until a few years ago, non-destructive testing and evaluation (NDT&E) considered only the detection of defects in components and products in the frame of quality assurance. Therefore, for many existing components, NDT&E has been often designed as an afterthought, rather than being an integral part of their design and manufacture.

This lesson has been learnt, and leads to three interesting paradigm changes in the area of NDT&E for nuclear applications:

- Materials and components need to be easily characterised and tested by means of NDT methods. Inspection-oriented material design has to be considered at manufacture, for the replacement of components or retrofitting.
- Ageing models, fed with data from continuous monitoring and in-service inspections, allow for predictive maintenance (as opposed to scheduled maintenance). **The question of how to aggregate and use such data has led to the development of digital replica or digital twins of components.**
- Continuous monitoring of the structural health of components has demonstrated its added value in other industries (such as aviation/aerospace) as a complement to in-



service inspections at programmed intervals, and is progressively making its way into the nuclear industry.

Today, NDT&E addresses more than the pure detection and locating of defects in components and infrastructure. NDT&E includes also the development of sensors suitable to capture production-related microstructural patterns and to merge them in the sense of an individual finger-print, a so-called "product DNA", deposited in "digital product files".

The sub-programme on **materials health monitoring and non-destructive examination for nuclear materials** in JPNM is a cross-cutting sub-programme with the subprogramms dedicated to Materials for ESNII demonstrators and prototypes, innovative high temperature resistant steels, refractory materials (ceramic composites, cermets and metal-based alloys), and physical modelling and modelling-oriented experiments for structural materials in EERA-JPNM and focuses on the in-situ characterization of the material degradation in the materials and the corresponding components addressed in the other subprogrammes of JPNM.

The proposed sub-programme within this tJP aims to carry out physical modelling activities jointly with definition, development, and optimization of multi-parameter non-destructive approaches for the in-situ characterization of the material degradation in materials and components for future NPPs, which enable to capture material properties (material DNA) right from the start of the material development until its end of life (end of operation).

All the activities reading below are being carried out as part of European projects such as:

- Metallic structural materials: M4F<sup>36</sup> (2017-2021), GEMMA<sup>37</sup> (2017-2021)
- Fuels: INSPYRE<sup>38</sup> (2017-2022), PUMMA (2020-2024), PATRICIA (2020-2024)
- Materials health monitoring: NOMAD<sup>39</sup> (2017 – 2021), ADVISE<sup>40</sup> (2017 – 2021), TeamCABLES<sup>41</sup> (2017 – 2022), or El Peacetolero (2020 -2024).

### 3.6.2 Objective

This new SP shall connect also with the digitalization trend in the nuclear (and not only) industry. This SP focused on physical modelling, materials health monitoring, and non-destructive examination for nuclear materials shall bridge the gap between materials microstructure, properties, processing parameters, modelling activities focused on aspects of in-service material degradation on one side and in-service inspection and condition monitoring of NPP components on the other side.

With respect to physical modelling activities, the ultimate goal is to set firmer grounds in the development of models and correlations allowing safe extrapolation of experimental data from laboratory to operating conditions, beyond purely empirical approaches of unassessable reliability. The physics-based models considered in this SP span all scales, from electronic structure calculations that make use of quantum mechanical approaches and physical-mathematical solving methods, to continuum models that use finite element solving methods. Modelling-oriented experiments using several advanced materials characterisation techniques are included. By looking carefully at the microstructural features and changes at different scales, examining materials after exposure beyond what is strictly needed for qualification, they aimed at providing information of physical mechanisms and correlation between changes at different scales. For a better understanding of mechanisms, the examination of model

---

<sup>36</sup> <http://www.h2020-m4f.eu/>

<sup>37</sup> <http://www.eera-jpnm.eu/gemma/>

<sup>38</sup> <http://www.eera-jpnm.eu/inspyre/>

<sup>39</sup> <https://nomad-coe.eu/>

<sup>40</sup> <https://www.advise-h2020.eu/>

<sup>41</sup> <https://www.team-cables.eu/>

materials and the use of target experimental campaigns aiming at discriminating between acting mechanisms are very helpful.

The main scientific research goals regarding MHM & NDE are related to the development and optimisation of intelligent NDE technologies including cognitive, auto-adaptive sensor technologies suitable for the characterisation of materials and components as well as for monitoring structures. A cognitive, auto-adaptive sensor shall be able to decide by itself which signals shall be measured and how to carry out the measurement. This requires a significant amount of a-priori knowledge available before each measurement and implemented AI to detect deviations from this priori information and measure these directly. Applying this concept leads to a significant reduction of irrelevant data, which aids the further analysis and processing of a now reduced data set. In this context, following topics connected with digitalization aspects, particularly Machine Learning (ML) and Artificial Intelligence (AI) algorithms for materials health monitoring and non-destructive examination can be addressed:

- Compilation of state of the art, gaps and needs related to ML and AI at European level
- Development and/or optimization of Machine Learning (ML) and Artificial Intelligence (AI) algorithms allowing for handling and for analysing MHM and NDE data generated in all stages of the entire product life cycle in digital twin files in a database for nuclear materials
- Development and application of models that allows for prediction of materials properties

*Conceptual models:* quantum-mechanical properties, semi-empirical methods, atomistic methods, mesoscale methods, Continuum methods.

*Numerical models:* quantum mechanics, ab-initio calculi, Monte Carlo calculi, molecular dynamics, finite elements method.

#### New paradigm related to SP1 and SP2

As it can be easily inferred from the previous sections, there is a strong link of collaboration with SP1 and SP2.

As aforementioned, multiscale modelling is pursued with several methodologies, ranging from quantum mechanical approaches and physical-mathematical solving methods, to continuum models that use finite element solving techniques. Also, use of big data and AI would be extremely useful to handle, select and analyse the large quantity of data yielded by the characterization of a very large number of samples using a large number of techniques. Image analysis is another specific concern.

### 3.6.3 Identified topics and expected output

Topic	Expected output	by	Expected deliverables
ML and AI in materials	Compilation of state of the art, gaps and needs related to ML and AI at European level	2021	Public report
ML and AI for MHM and NDE	Development and/or optimization of ML and AI algorithms allowing for handling and for analysing MHM and NDE data generated	2022	Code sources uploaded in repositories (GitHub)

Digital twins database	Compilation of the entire product life cycle in digital twin files in a database for nuclear materials	2024	Database available
ML and AI for prediction of materials properties	Development and application of models that allows for prediction of materials properties	2024	Reports and publications

Table XI: Identified topics and expected output for the NM tSP

### 3.6.4 Contacts

<i>Company name</i>	Commissariat à l'énergie atomique et aux énergies alternatives
<i>Contact person</i>	Dr. Marjorie Bertolus
<i>Postal address</i>	Bâtiment 103 Saint-Paul-Lez-Durance Cedex 13108 France
<i>Country</i>	France
<i>E-mail</i>	marjorie.bertolus@cea.fr
<i>Telephone</i>	+ 33 4 42 25 70 00

<i>Company name</i>	Fraunhofer Institute for Nondestructive Testing IZFP
<i>Contact person</i>	Dr. Madalina Rabung
<i>Postal address</i>	Campus E3 1, 66123 Saarbruecken
<i>Country</i>	Germany
<i>E-mail</i>	madalina.rabung@izfp.fraunhofer.de
<i>Telephone</i>	+49 (0)681 9302 3882

Table XII: Identified contacts for the NM tSP

## 4 Management

As aforementioned, the management of the tJP has been conceived for avoiding the overload of managerial structures within EERA and creating real added value. Then, the management structure is fully lightweight and is only composed of a Management Board formed (MB) by the JP Coordinator (JPC), a Deputy (DJPC), and the SPs coordinators belonging to the tJP<sup>42</sup>.

This structure will provide an agile management and a direct interaction between all the JPs with interests in digitalization. Also, it will have a fluent first-hand interaction with the activities being developed by the different EERA groups.

For high-level managerial duties, the SC is constituted by the EERA President, Vice-President(s), and Secretary General, who will consult the ExCoop when necessary. By doing so, the cross-cutting and transdisciplinary approach within EERA of this tJP will be reinforced and additional layers are avoided.

The JP on Digitalization for Energy will interact/interface with all the actors/initiatives/bodies playing a key role in Europe in those topics addressed by EERA, in particular:

- The EERA ExCoop, as the consulting body of the tJP SC
- The EERA JPs, through the SPs belonging to this tJP and the periodic JPC meetings
- The EERA SET-Plan bodies
- The EERA Secretariat
- The Horizon Europe officers, in particular those with interests in digitalization and/or energy
- Major European technology platforms, such as ETP4HPC, BDVA, etc.
- The EuroHPC joint undertaking (and their precursor PRACE)
- The EOSC initiative promoted by the European Commission
- European projects and initiatives such as EoCoE-II, EERAdata, POP, and any other with interests in digitalization and/or energy

With respect to the milestones related the management of the tJP, they are listed in Table XIII.

Topic	Expected output	By	Expected deliverable
Kick-off of the tJP	Official kick-off of the tJP if approved by the EERA General Assembly (GA)	2020	GA minutes (public)
Formation of the MB	Formation of the tJP DfE MB	2020	Minutes of the 1 <sup>st</sup> MB meeting (intern)
Website	Implementation and publication of the tJP website (to be linked and integrated into the EERA one)	2021	Website (public)
Questionnaire for new members and tSPs	Edition of a questionnaire to be filled by new members and tSPs wishing to be part of the tJP	2021	Questionnaire (public)
List of secondments	Provision of a table for the year in which secondments could be hosted by several institutions detailing the techniques to be taught	2021	Table (intern)

<sup>42</sup> The management of the tJP is in any case subject to the provisions of EERA Statutes and IROPs

EC DG Energy	Support the EERA SG for an open seamless communication with DG Energy	2021	Report (intern)
HE Calls	Identification of Horizon Europe Calls that could be of interest for the members of the tJP. Definition of a procedure for building strong submitters consortiums.	2021	Table (intern)
EnerDigit Call	Potential collaboration with the EnerDigit ERA-NET for defining future calls of interest to DfE.	2021	Table (intern)
Annual conference	Organization of the yearly tJP DfE conference	2021	Report (public)
Map of numerical codes and repositories	The objective is to count on a map in which the codes and repositories of interest to EERA activities is depicted.	2021	Report (public)
Digital methodologies	The objective is to count on a report of the transdisciplinary digital methodologies that can be exploited by the EERA groups.	2021	Report (public)
Periodic report	Report of the activities carried out by the tJP along the year	2021	Report (public)

Table XIII: Managerial milestones of the tJP on DfE. Intern aspect refers to EERA.

## 4.1 Resources

In what follows, a description of the resources to be pledged to this tJP is detailed. It will list the institutions involved in the tJP, the human resources provided in terms of person per year (ppy), and the digital infrastructure and facilities that will be made available.

### 4.1.1 Participants

By default, the list of institutions participating in the tJP DfE is that of EERA members, i.e. every EERA member is part of this tJP in which will maintain their status as either Full or Associate member. Institutions not being part of EERA can collaborate with this tJP, but not become member.

As those of Oct 2020, the list of participants is composed of EERA members already involved in any of the tSPs and those EERA members who have simply requested to be involved in SP1, SP2, or both. The notification of their participation in the tJP will be done by replying in that sense to the communication made by EERA on the open and transparent call for candidates to JPC, Deputy, SP1 coordinator and SP2 coordinator (see section 4.3.1 below).

For the future, i.e. beyond Oct 2020, any EERA member will become member of this tJP by becoming part of any of the tSPs or by following the procedure described in section 4.2 below.

The list of participants is:

- CEA (SP1)
- CIEMAT (SP1, SP2, NM tSP)
- DIFFER (AMPEA tSP)
- DLR (AMPEA tSP)
- DTU (ESI tSP)
- ENEA (SP2, AMPEA tSP)
- Helmholtz-ISZP (NM tSP)
- HVL (SP2)
- Manchester Univ (NM tSP)
- NORCE (ESI tSP)
- SINTEF (AMPEA tSP)

- Lorraine Univ. (AMPEA tSP)
- Tecnalia (SP2)
- VTT (ESI tSP, AMPEA tSP, NM tSP)
- Wien Tech. Univ. (Hydro tSP)

#### 4.1.2 Infrastructures and facilities

The list of the Infrastructures and facilities made available to the tJP DfE as those of Fall 2020 is included in Table XIV. It is still much short, but it will be enlarged in the near future once the different partners will start working.

Short Name (Institution)	Infrastructure: technical characteristics	Access Type
ACME (CIEMAT)	HPC cluster composed of 720 Intel Gold cores and 24,576 NVIDIA cores. 1 storage server composed of 37 disks (131 TB raw storage).	For joint efforts
CRESCO (ENEA)	CRESCO6 (434 nodes for a total of 20832 cores, each node 2 Intel Xeon Platinum 8160 CPUs, each with 24 cores with a clock frequency of 2.1 GHz, > 1 PFlop/s ) and CRESCOX 45 x (2 Power8+4 Tesla P100, 1 PFlop/s)	For joint efforts
The different tSPs contribute with their own resources listed in their DoWs and SRIAs.		

Table XIV: List of the Infrastructures and facilities made available to the tJP DfE.

## 4.2 Committees and Boards

The tJP DfE is structured into two main bodies (see Fig. 4), whose tasks and purpose are detailed below:

- Steering committee (SC), a role played by the EERA President, Vice-President(s), and Secretary General, that meets every six months as part of ExCoop
- Transversal Joint Programme Management Board, which includes the Coordinator, a Deputy, and one participant of each participating SP. If needed, the JPC could be assisted by a kind of Programme Secretary (JPS) played by someone from the EERA Secretariat, though direct support will be carried out by the Deputy
  - The MB will meet every six months to monitor the tJP advances and design further steps; such meetings will be aligned with the ExCoop meetings
  - The JPC (or the Deputy) will participate in the EERA meetings in which he/she will be convened

Participation in and contribution to the tJP DfE is open to every SP belonging to an ongoing EERA Joint Programme and will develop activities on digitalization. The admission of a new SP to the tJP DfE follows a rather straightforward procedure, i.e. to make an informal application with the JPC describing those digital methodologies and techniques applied (or planned to be applied) by groups belonging to the SP. Later on, on the next tJP MB meeting the integration of this potential new SP will be approved as the first point of the agenda, so from that moment on, the SP representative will be able to participate in the meeting as a regular member.

Participation in and contribution to the tJP DfE is open to new members, who will be integrated into one of the ongoing SPs of the tJP. Participants have to previously join the EERA either as Full Participants (Participants) or as Associate Participants (Associates). Details of the membership status are explained and fixed by the EERA AISBL for all EERA joint programmes<sup>43</sup>.

<sup>43</sup> [www.eera-set.eu](http://www.eera-set.eu)

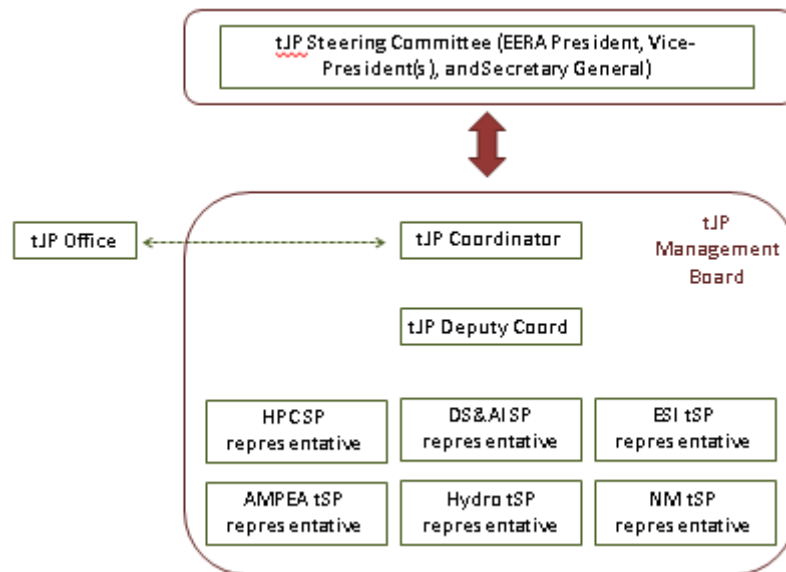

Figure 4. Managerial structure of the tJP on DfE.

The admission of a new either Full Participant or Associate participant to the JP DfE follows the following procedure<sup>44</sup>:

- The applicant has to approach the JPC, who will provide him/her with a questionnaire to be filled out. Such a questionnaire is prepared to collect information on the applicants' areas of expertise, current activities, their potential contributions to the tJP DfE, and the SP(s) of interest. The applicant should deliver back the filled out questionnaire to JPC within three weeks
- Once the questionnaire is received, the applicant will be invited to present their institutions at a MB meeting
- Recommendations about the approval are made by the MB; these recommendations are transmitted to the JP SC which finally approves the admission to the JP

Voting and managerial rights are limited to members of the MB, who have a collective responsibility for the accomplishment of the programme objectives.

In order to properly develop the tJP activities and co-fund the costs of joint programme coordination, no annual fee will be collected as the EERA AISBL Secretariat will cover the associated costs for the first year. Once this period will be over, an evaluation by the EERA Secretariat, in accordance with Joint Programme MB, will be done in order to apply potential changes if needed.

## 4.3 EERA Officers

### 4.3.1 Joint Programme Coordinator (JPC)

The Joint Programme Steering Committee selects the Joint Programme Coordinator after open and transparent call for candidate. Such a call for candidate will be ruled this way:

- A call for applicants will be sent to all tJP DfE participants.
- The SC will appoint a candidate on basis of recommendation letters received from organisations participating to the tJP-DfE.
- Only Full EERA members participating in at least one of the tSPs may provide a recommendation letter for a candidate

<sup>44</sup> As those of Oct 2020, this procedure slightly defers from existing IROPs due to the transversal nature of the JP, so it must be approved by the EERA ExCo.

The JPC coordinates the JP, chairs the MB, and reports to the SC.

The duration of the mandate of the JPC initially is from Oct 2020 to Oct 2021, which can be automatically renewed for one more year by the SC. From that moment on, the duration will be of 2 years following the call procedure aforementioned.

The associated tasks and responsibilities are:

- Coordination of the scientific activities in the tJP and communication with the SC and the EERA Secretariat
- Monitoring of progress in reaching targets and milestones in the tJP and each SP, identifying bottlenecks and risks, and proposing contingency plan actions
- Reporting on scientific progress and unexpected developments to the EERA secretariat and the EERA ExCoop
- Coordination of the overall planning process and progress reporting
- Interaction with relevant industry and scientific initiatives (e.g. KICs,..)
- Representation of the EERA tJP DfE in the European SET-Plan related committees.

The JPC is mainly assisted by the Deputy, and if needed, a person from the EERA Secretariat could act as a kind of Joint Programme Secretary (JPS) for specific issues related to the EERA governance. A Joint Programme Office (JPO) already hosted and funded by the JPC's institution might support the JPC and the MB.

#### **4.3.2. Deputy Joint Programme Coordinator (DJPC)**

The Joint Programme Steering Committee selects the Deputy Joint Programme Coordinator after open and transparent call for candidate, which will follow the same procedure described for the JPC and will be carried out at the same time. The DJPC assists the JPC in his/her related duties and represents the tJP in those fora in which the JPC will not be able to attend, inheriting the tasks and responsibilities in those cases.

#### **4.3.3. Subprogramme Coordinator (SPC)**

The SC selects Subprogramme Coordinators (SPC). For the SPs only belonging to this tJP, i.e. SP1 and SP2 as those of Oct 2020, they will be selected after open and transparent call for candidates, which will follow the same procedure described for the JPC and will be carried out at the same time. For the tSP coming from other JPs, the respective JPC will propose candidates to be confirmed by the SC. The SPCs are responsible for the coordination of a subprogramme and reporting to the JPC.

The duration of the mandate of the SPCs initially is from Oct 2020 to Oct 2021, which can be automatically renewed for one more year by the SC. From that moment on, the duration will be of 2 years following the call procedure aforementioned

Their tasks and responsibilities are:

- Coordination of the scientific activities in the SP to be carried out by the participants according to the agreed commitment. The SPC communicates with the contact persons to be assigned by each participant
- Monitoring progress in reaching the SP's targets and milestones
- Reporting progress to the JPC
- Propose and coordinate scientific plans for the SP for the planning period
- Monitor scientific progress and report unexpected developments in terms of depleting, identifying financial means or technical or scientific bottlenecks

### **4.4 Bodies of EERA tJP DfE**

#### **4.4.1. Steering Committee (SC)**

The SC has the final responsibility to take all the EERA high-level collective decisions necessary for the functioning of the tJP DfE, so it only monitors the accomplishment of its objectives and



propose contingency actions, if required. Any decisions are taken when requested or proposed by a MB member.

The composition of the SC is that of the EERA President, Vice-President(s), and Secretary General. The Secretary General is a neutral position who is expected to provide a better hands on knowledge of the situation to the rest of the SC. The SC will consult the ExCoop as required.

New Participants and Associates are recommended by the MB and have to be approved by the SC.

Decisions in the SC are taken in a similar way to those ruling the ExCoop. Approval or rejection of recommendations made by the MB can also be done by e-mail voting. If a vote is not cast within two weeks, approval of the recommendation is assumed.

The SC tasks and responsibilities are approval of the tJP DfE's:

- Annual work plan, budget, and allocation of resources of participants to the tJP
- Annual progress report
- Modifications of the SRIA

#### **4.4.2. Joint Programme Management Board (MB)**

The MB has the responsibility to take all collective decisions necessary for the functioning of the tJP DfE and accomplishment of its objectives. Any decisions are taken when requested or proposed by a Participant or by the JPC.

The MB is responsible for all management aspects of the tJP. The MB is chaired by the Joint Programme Coordinator (JPC), flanked by a Deputy. The MB might be assisted by a Joint Programme Office (hosted and funded by the JPC's institution), which is directed by the JPC. In addition, the MB has the responsibility to safeguard the scientific quality, and societal and industrial relevance of the joint programme.

The MB consists of the JPC, a Deputy, and one representative by participating SPs (might several SPs from the same JP join this tJP, they will join in a unique tSP). These people are appointed by the SC following the rules previously defined.

Members of the MB are appointed for periods of two years (with the exception reading before about the period Oct 2020 – Oct 2022).

The tasks and responsibilities assumed by the MB are:

- Financial and contracts management
- Pursuing implementation of Intellectual Property Rights (IPR), enforcing the EERA IP guidelines, following the best practice of the EU Framework Programmes, in particular Horizon Europe and future Framework Programmes
- Scientific coordination and joint programme progress control
- Planning on programme and sub-programme level
- Recommendation of new participants and SPs subject to confirmation by the SC
- Internal communication (reports, conference, workshops, proposals, etc.) and networking activities
- Dissemination, outreach, and promotion actions of the tJP towards 3 targeted audiences: (1) Partners & Associates, (2) Decision Makers, Companies, and major initiatives; and, (3) Public audience

#### **4.4.3. Subprogramme management team (SPMT)**

The SP management team (SPMT) is responsible for the execution of an individual tJP DfE subprogramme.

For those SPs which solely belong to the tJP, the SP management team consists of the Tasks leaders in which the SP is structured and the SPC, who heads the SPMT. For the appointment of the team, the SPMT is decided upon by the MB.

For those SPs coming from other JPs, composition and appointment rules follow those of the associated JP.

The tasks and responsibilities of the SMPTs are:

- elaboration of proposals of annual work plans
- execution of annual work plans
- reporting to the MB
- adjustment of work plan, based on internal progress and recommendations by the MB
- Convenes when necessary

#### **4.4.4. Members of the JPMB appointed by the JPSC**

In Dec 2020, the aforementioned open call for nominating the JPMB was carried out by the EERA Secretariat. The final decision of the JPSC after receiving several letters of support was the following:

- JP Coordinator: Rafael Mayo-Garcia (CIEMAT)
- Deputy JP Coordinator: Massimo Celino (ENEA)
- SP1 (High Performance Computing): Edouard Audit (CEA)
- SP2 (Data Science and Artificial Intelligence): Valeria J. Schwanitz (HVL)
- ESI tSP “Technology”: Peter Breuhaus (NORCER)
- AMPEA tSP “Multiscale modelling of materials, processes and devices”: David Lacroix (U. Lorraine)
- Hydropower tSP “Digitalization”: Eduard Doujak (TU Wein)
- Nuclear Materials tSP “Physical modelling, materials health monitoring and non-destructive microstructure examination for nuclear materials”: Marjorie Bertolus (CEA)

In addition, the EERA Secretariat has appointed Ganna Gladkykh (Clean Energy Transition expert) as central support from EERA AISBL.

This MB will coordinate the tJP for the first year till Oct 2021. From that moment on, it could be extended for one more year, opening periodic new calls for 2-year position afterwards.

## 5 Risks

When EERA started working on assessing the suitability of this tJP, one of the main issues to be tackled was to identify the weaknesses and risks that could difficult the work to be done. This activity was properly approached through the questionnaire surveyed to the EERA JPCs.

Taking those answers into account and other facts raising from the contributors to this DoW, several major risks need to be managed:

- This tJP, by its nature, encompasses a wide scope: the objectives and paths to follow have to be made precise enough to permit the work to be focused, and the progress to be correctly assessed.
- The fundamental type of research, which will be the business of DfE, is also the business of many labs in universities, research centres, companies, etc. DfE shall not work isolated, knowing the efficiency of competition among many teams, for new ideas to appear. An open-minded relation shall develop especially with the EERA actors and entities, but also with external bodies.
- By pursuing long term technological goals, DfE will take the risk that the carried out research be made obsolete by new progress in already industrialised techniques. A way to avoid this is to look for enabling capacities, applicable to many fields, beside the technological goals: DfE is made of both basic cross-cutting subjects of generic interest, and long term applied goals.
- There is a potential disconnection and time spent to provide solutions as the groups involved could be more focused on other activities. That is why all the SPs belonging to this tJP are requested to identify external funded projects aligned with the goals reading this document.
- Duplicity could arise from the fact that many EERA groups (either belonging to this tJP or not) could be developing similar solutions. Topics such as ‘Map of numerical codes and repositories’ and ‘Digital methodologies’ reading in Table XIII are defined as contingency plans.

## **6 Intellectual Property Rights of the tJP**

The tJP DfE follows the default procedures made available by the EERA secretariat. The EERA policy on IPR is accepted based on seven principles:

1. Ownership of results and inventions remain with the inventing institutions.
2. Results must be protected where appropriate.
3. Background knowledge should be available to EERA projects.
4. Access to project generated knowledge should be available to other EERA projects.
5. Licensing should generally be non-exclusive.
6. Joint commercialisation should be pursued where possible.
7. EERA aims for commercialization in a global energy technology arena.

## 7 Contributors

Andresen, Christian Andre (SINTEF)  
Bertolus Marjorie (CEA)  
Bieberle, Anja (DIFFER)  
Breuhaus, Peter (NORCERESEARCH)  
Celino, Massimo (ENEA)  
Doujak, Eduard (T. U. WIEN)  
El Gammal, Adel (EERA)  
Ihssen, Holger (Helmholtz)  
Lacroix, David (U. LORRAINE)  
Longuere, Kajsja-Stina (UCL / UKERC)  
Matejak, Ivan (EERA)  
Mayo-García, Rafael (CIEMAT)  
O'Sullivan, Aidan (UCL / UKERC)  
Pareige, Cristelle (U. ROUEN)  
Rabung, Madalina (FRAUNHOFER IZFP)  
Ramalho, Maria (FZ-JUELICH)  
Schwanitz, Valeria Jana (HVL)  
Suna, Demet (AIT)  
Wierling, August Hubert (HVL)